

TECHNICAL MANUAL

**DS, GS, AND DEPOT MAINTENANCE
MANUAL
CAMERA SETS, STILL PICTURE
KS-19A4 AND KS-19B**

**HEADQUARTERS, DEPARTMENT OF THE ARMY
DECEMBER 1970**

CHANGE }
No. 1 }

HEADQUARTERS
DEPARTMENT OF THE ARMY
WASHINGTON, D.C., 17 April 1973

Direct Support, General Support, and
Depot Maintenance Manual
CAMERA SETS, STILL PICTURE KS-19A4 AND KS-19B

TM 11-6720-248-35, 31 December 1970, is changed as follows:

1. The title is changed as shown above.
2. Remove old pages and insert new pages as indicated below.

<i>Remove pages--</i>	<i>Insert pages--</i>
7-3 and 7-4	7-3 and 7-4
3. File this change sheet in front of the publication for reference purposes.

THIS PUBLICATION IS A COURTESY QUICK COPY FROM THE UNITED STATES ARMY PUBLICATIONS DISTRIBUTION CENTER, ST. LOUIS, MISSOURI, TO MEET YOUR NEEDS WHILE WE REPLENISH OUR REGULAR STOCK.

By Order of the Secretary of the Army:

CREIGHTON W. ABRAMS
General, United States Army
Chief of Staff

Official:

VERNE L. BOWERS
Major General, United States Army
The Adjutant General

Distribution:

Active Army:

USASA (2)
 CNGB (1)
 ACSC-E (2)
 Dir of Trans (1)
 COE (1)
 TSG (1)
 DCSLOG (1)
 USAARENBD (2)
 USAMB (10)
 USACDC (2)
 USACDC Agcy (1)
 AMC (1)
 CONARC (5)
 ARADCOM (2)
 ARADCOM Rgn (2)
 OS Maj Comd (4)
 LOGCOMD (5)
 MICOM (4)
 TECOM (2)
 USASTRATCOM (4)
 HISA (ECOM) (70)
 MDW (1)
 Armies (2)
 Corps (2)
 Svc Colleges (2)
 USASESS (10)
 USAADS (2)
 USAFAS (2)
 USAARMS (2)
 USAIS (2)
 USAES (2)
 USAINTS (3)
 WRAMC (1)
 USACDCEC (10)
 USMA (2)
 ATS (1)

Instl (2) except
 Fort Gordon (10)
 Fort Huachuca (10)
 Fort Carson (15)
 Fort Bragg (5)
 Fort Campbell (5)
 Ft Richardson (ECOM Ofc) (2)
 WSMR (3)
 Army Dep (2) except
 LBAD (14)
 SAAD (30)
 TOAD (14)
 LEAD (7)
 NAAD (5)
 SVAD (5)
 ATAD (10)
 USA Dep (2)
 Sig Sec USA Dep (5)
 Sig Dep (10)
 Sig FLDMS (2)
 USAERDAA (2)
 USAERDAW (5)
 USACRREL (2)
 MAAG (1)
 USARMIS (1)
 USA Crim Inves Lab (3)
 Units org under fol TOE:
 (2 copies each)
 11-95
 11-96
 11-1
 11-500 (AA-AC, FD & FE)
 29-134
 29-136

NG: None

USAR: None

For explanation of abbreviations used, see AR 310-50.

TECHNICAL MANUAL }
 No. 11-6720-248-35 3

HEADQUARTERS
 DEPARTMENT OF THE ARMY
 WASHINGTON, D.C., 31 December 1970

**DS, GS and Depot Maintenance Manual
 CAMERA SETS, STILL PICTURE KS-19A4 AND KS-19B**

		Paragraph	Page
CHAPTER	1. INTRODUCTION -----	1-1-1-3	1-1
CHAPTER	2. FUNCTIONING OF CAMERA SET		
Section	I. Block diagram theory -----	2-1-2-9	2-1-2-5
	II. Circuit analysis -----	2-10-2-14	2-6-2-12
CHAPTER	3. DIRECT SUPPORT MAINTENANCE		
Section	I. General -----	3-1, 3-2	3-1
	II. Troubleshooting -----	3-3, 3-4	3-1, 3-2
	III. Repair and adjustment -----	3-5-3-18	3-4-3-15
CHAPTER	4. DIRECT SUPPORT TESTING PROCEDURES -----	4-1-4-3	4-1-4-3
CHAPTER	5. GENERAL SUPPORT MAINTENANCE -----	5-1-5-8	5-1-5-4
CHAPTER	6. DEPOT MAINTENANCE		
Section	I. General -----	6-1-6-3	6-1
	II. Troubleshooting -----	6-4-6-7	6-1-6-3
	III. Repair procedures -----	6-8-6-16	6-7-6-12
	IV. Testing -----	6-17-6-20	6-15, 6-16
CHAPTER	7. DEPOT OVERHAUL STANDARDS		
Section	I. General -----	7-1, 7-2	7-1
	II. Test equipment and tests -----	7-3-7-6	7-1
	III. Strobe assembly tests -----	7-7, 7-8	7-2, 7-3
	IV. Camera assembly tests -----	7-9	7-4
	V. External battery charger tests -----	7-10	7-7
APPENDIX	A. REFERENCES -----		A-1
INDEX	-----		I-1

LIST OF ILLUSTRATIONS

Number	Title	Page
2-1	Camera set, block diagram-----	2-2
2-2	Optical function diagram -----	2-3
2-3	SCR control assembly, block diagram-----	2-4
2-4	Model 600 strobe, block diagram -----	2-4
2-5	Model 700 strobe, block diagram -----	2-6
2-6	External battery charger, block diagram -----	2-6
2-7	SCR control assembly, schematic diagram -----	2-7
2-8	Model 600 strobe assembly, schematic diagram -----	2-9
2-9	Model 600 Strobe assembly power mode waveform-----	2-10
2-10	Model 700 strobe assembly schematic diagram -----	2-11
2-11	Lens and shutter assembly, interior view -----	2-13
2-12	External battery charger, schematic diagram -----	2-13
3-1	Camera set, exploded view -----	3-5
3-2	Camera assembly, exploded view-----	3-9
3-3	Camera back assembly, exploded view-----	3-10
3-4	Door assembly A10, exploded view-----	3-11
3-5	Frame roller support assembly A39, exploded view-----	3-12
3-6	Tripod assembly, exploded view -----	3-13
3-7	Support arm assembly, exploded view -----	3-14
3-8	External battery charger, exploded view -----	3-16
3-9	Terminal board assembly A50, exploded view -----	3-17
5-1	Lens and shutter assembly, exploded view -----	5-3
5-2	Lens and shutter assembly test setup -----	5-5
5-3	Shutter speed and flash, synchronization waveforms-----	5-6
6-1	Model 600 anode voltage check -----	6-5
6-2	Model 600 strobe assembly waveforms-----	6-6
6-3	AC input test setup -----	6-6
6-4	Model 700 anode voltage check -----	6-7
6-5	Model 600 strobe assembly, exploded view-----	6-8
6-6	Model 600 circuit card assembly, exploded view -----	6-9
6-7	Model 600 strobe assembly, wiring diagram -----	6-10
6-8	Model 700 strobe assembly, exploded view-----	6-11
6-9	Model 700 ac power cord assembly-----	6-12
6-10	Model 700 strobe assembly, wiring diagram -----	6-13
6-11	Model 700 circuit card assembly No. 1 -----	6-14
6-12	Model 700 circuit card assembly No. 2 -----	6-15
6-13	Resistor-Capacitor color code chart-----	6-19

CHAPTER 1 INTRODUCTION

1-1. Scope

a. This manual covers field and depot maintenance for Camera Sets, Still Picture, types KS-194A and KS-19B, hereafter referred to as the camera set. The manual includes instructions appropriate to DS, GS, and depot support for trouble-shooting, testing, alignment, and repairing the equipment, replacing maintenance parts, and repairing specified maintenance parts. It also lists tools, materials, and test equipment for DS, GS, and depot support maintenance. Detailed functions of the equipment are covered in chapter 2.

b. The complete technical manual for the camera set consists of TM 11-6720-248-12 and this manual.

1-2. Reporting of Equipment Manual Improvements

Reporting of errors, omissions, and recommendations for improving this manual by the individual user is

encouraged. Reports should be submitted on DA Form 2028 (Recommended Changes to DA Publications) and forwarded direct to Commanding General, U. S. Army Electronics Command, ATTN: AMSEL-ME-NMP-EM, Fort Monmouth, N. J. 07703.

NOTE

Applicable forms and records are covered in chapter 1, TM 11-6720-248-12.

1-3. Indexes of Equipment Publications

a. *DA Pam 310-4.* Refer to DA Pam 310-4 to determine whether there are new editions, changes, or additional publications pertaining to the equipment.

b. *DA Pam 310-7.* Refer to DA Pam 310-7 to determine whether there are modification work orders (MWO's) pertaining to the equipment.

CHAPTER 2 FUNCTIONING OF CAMERA SET

Section I. BLOCK DIAGRAM THEORY

2-1. General

This section provides block diagram analysis of the overall operation of the camera set and of individual units: the camera assembly, the flash unit assembly (hereafter called the strobe assembly), and the stereoscopic attachment. The camera set contains a tripod also, but the theoretical description in this chapter is limited to operating controls.

2-2. Camera Set, Block Diagram Theory (fig. 2-1)

a. Image Characteristics. The block diagram illustrates operating principles of the camera set. The subject includes the titleboard, which is held in place by the horizontal positioning bar, which also fixes lens-to-subject distance, and focus.

b. Exposure Control. For color or black and white film, the exposure is adjusted by selection of aperture and shutter speed. For black and white film, a coarse exposure adjustment is made also; by attaching a density filter on the camera assembly and both of the strobe assemblies. When the shutter is tripped, a shutter switch in the lens and shutter assembly triggers an SCR control, which triggers both strobe assemblies.

c. Strobe Operation. Two strobe assemblies are included in each camera set, either model 600 or model 700. The strobes are fully interchangeable as long as the ac cords and neutral density filters are interchanged with the strobe. Each strobe has two external receptacles, one for triggering and one for the ac power cord. The battery charger is inside the strobe housing on the model 600 and is an integral part of the ac cord connector on the model 700. The model 600 strobe has a three-position switch for selecting battery only, ac, and battery charge operation; the model 700 is automatically selected depending on whether the ac cord is attached and uses an ON-OFF switch only. The model 700 also incorporates an "Open Flash" switch. Either model strobe attaches to the support arm assembly and shutter cords for SCR controlled

operation.

d. Film Transport. The Land system of photography is used. Film transport and advance is accomplished manually by drawing a paper leader from the back assembly. Film packs are used that provide the film frame and film pressure plate. The back assembly supplies locating and pressure points to align the pack with the optical axis of the camera assembly.

e. External Battery Charger. Only those camera sets provided with model 700 strobe assemblies are equipped with an external battery charger. It operates from the 115-volt ac line with a timer to charge four battery trays simultaneously. Battery trays from either the model 600 strobe or model 700 strobe may be charged to provide additional support for camera sets in high volume operations. The timer has a total time of 12 hours with a scale in 1-hour increments, a pilot lamp indicates when charger is in operation.

2-3. Mechanical Functions

a. General. This is a description of the mechanical operation of the camera set. Refer to figure 3-1 for detailed illustrations of components.

b. Camera Set. The horizontal positioning bar is a measuring rod and support, attached to the front of the camera assembly. It is used to preset lens-to-subject distance and to support the titleboard. The tripod inner tube is adjusted for vertical height. To prevent double exposure, a shutter latch captures the shutter release lever when the shutter actuate button is depressed. The latch continues to hold the shutter release lever in the down position until the back assembly is rotated to bring the second half of the film frame into position. The back assembly drives a lever assembly as it rotates and depresses the shutter latch allowing the shutter mechanism to return to its static position; this also cocks the shutter. There are no devices for mechanical film advance.

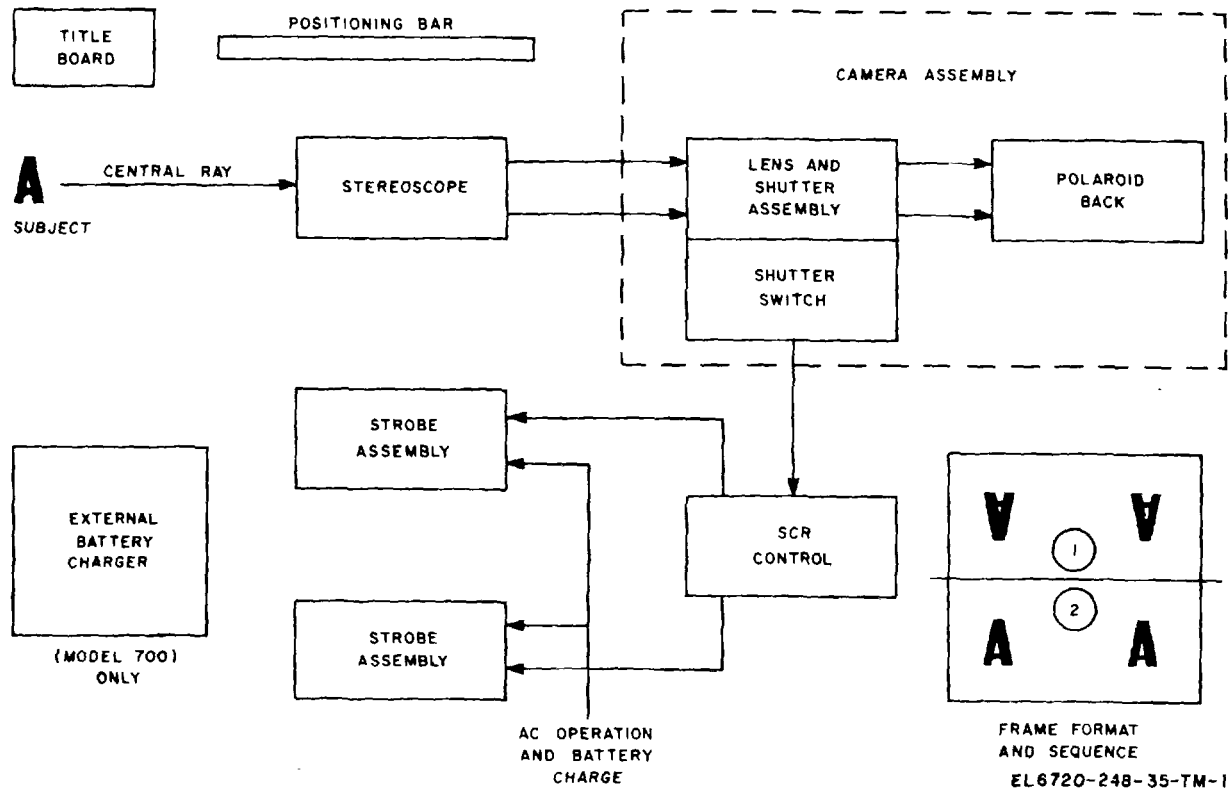

Figure 2-1. Camera set, block diagram.

The back assembly is constructed as an adaptor to accept Land film packs, which are loaded without need for spooling.

2-4. Optical Functions
(fig. 2-2)

Figure 2-2 illustrates the formation of the dual image on the film plane. The stereoscopic attachment produces two isolated images, which appear before the camera assembly side-by-side, with the same lateral aspect as the subject, and without inversion. A reciprocating leaf shutter and iris diaphragm are used between the lens sections to control exposure. It is a conventional assembly in principles, self-cocking, and with a fixed-focus lens system. The iris diaphragm is used with the shutter speeds to adjust exposure. A shutter switch is actuated by the shutter mechanism to trigger the strobe assemblies.

2-5. Control Functions

a. *Tripod.* The tripod has two hand-operated knobs for controlling the clamps on the tripod. The lower (legs hinge clamp screw) is used to set up the tripod.

The upper (telescope clamp screw) is used to position and lock the camera assembly at the desired height. The telescoping inner tube of the tripod is spring-loaded to assist in raising the camera assembly when the clamp screw is released. Also, the inner tube may be rotated to pan the camera.

b. *Lens and Shutter Assembly.* A shutter speed control ring at the front of the lens barrel is used to select three shutter speeds plus time and bulb. The diaphragm is adjusted by the iris diaphragm control lever (a tab extending from the side of the lens barrel). The shutter release mechanism is operated by a finger-actuated plunger, fitted with a pin that extends into the lens barrel. (There is no cable release.) The shutter release lever extends from the lens barrel and operates in unison with the actuate button. It moves down to become engaged with the double-exposure prevention device.

c. *Camera Back Assembly.* The back assembly is rotated to select the half frame desired. As it is rotated, it drives a lever assembly, which depresses the double-exposure prevention device to

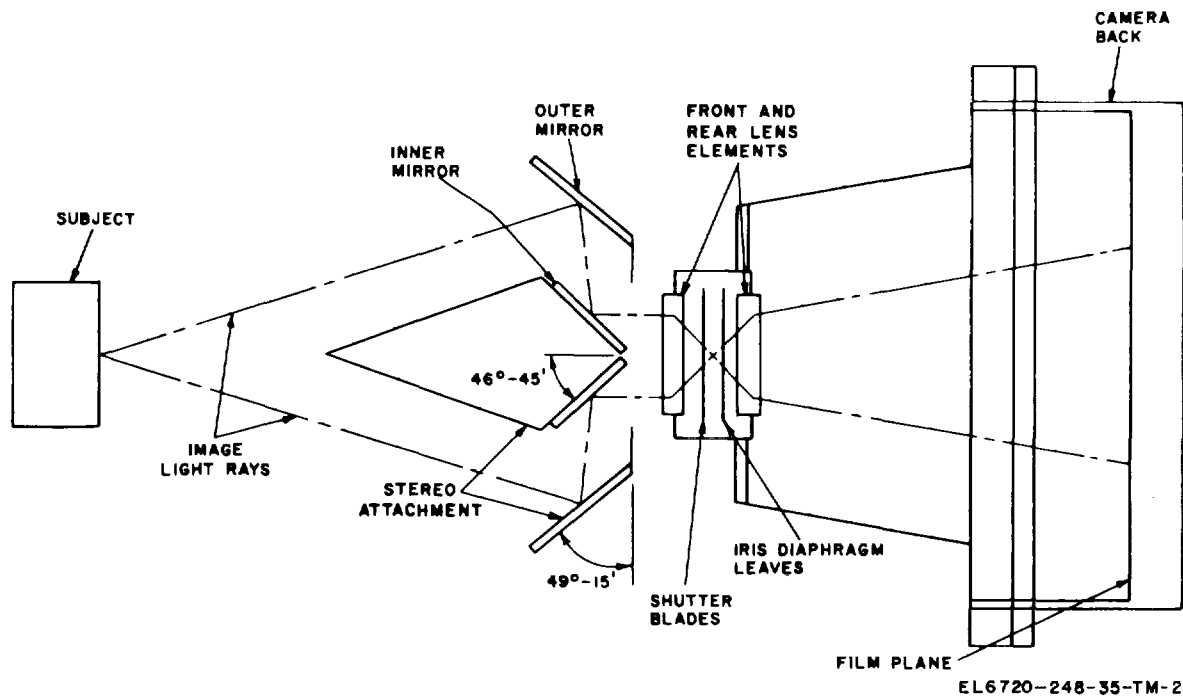

Figure 2-2. Optical functions, block diagram.

release the shutter mechanism and recock the shutter. The rotating back is detented for positive positioning. There is a release latch on the side of the back assembly to allow opening of the back for film handling. The back assembly has two doors; the larger for loading the film, and the smaller for access to a storage compartment in which the density filter is kept. This smaller door is held closed with a spring catch.

d. *Horizontal Positioning Bar.* This combines the functions of a measuring rod and a support bar to hold a titleboard in the desired relationship with the subject. The titleboard is supported by the titleboard holder; a device with a spring-loaded hook mounted at the end of the horizontal positioning bar.

e. *Strobe Assemblies.* Two strobe assemblies are included with each camera set; either model 600 or model 700. Either model is mechanically and electrically interchangeable as long as the accords are interchanged. The strobes are attached to the support arm assembly by spring clip and dog. Release from the support arm is accomplished by depressing the spring clip release button. The model 600 strobes have density filters cemented to the lens while the model 700 has density filters removable by a quarter-turn slot provided in the lens frame.

2-6. SCR Control Assembly, Block Diagram Description

(fig. 2-3)

The shutter switch in the lens and shutter assembly is a single-pole, normally-open switch. When actuated, connection is made from the positive pole of the battery, which supplies the gating voltage for the silicon-controlled rectifiers (SCR). This provides continuity in both output circuits for triggering the strobe assemblies.

2-7. Model 600 Strobe, Block Diagram Description

(fig. 2-4)

a. *General.* The model 600 strobe is operated by the internal battery pack, or by ac line voltage. Battery operation utilizes an oscillator circuit to convert battery voltage to high voltage dc, which is stored in a capacitor for discharge to the strobe flash tube. Ac operation does not use the oscillator, but a voltage multiplier circuit to generate high-voltage dc. A selector switch selects these two modes, or a service mode for charging the batteries. The battery charger is contained in the strobe assembly and operates off ac line voltage.

b. *Battery Operation.* From the selector switch, the battery voltage is applied to the oscillator

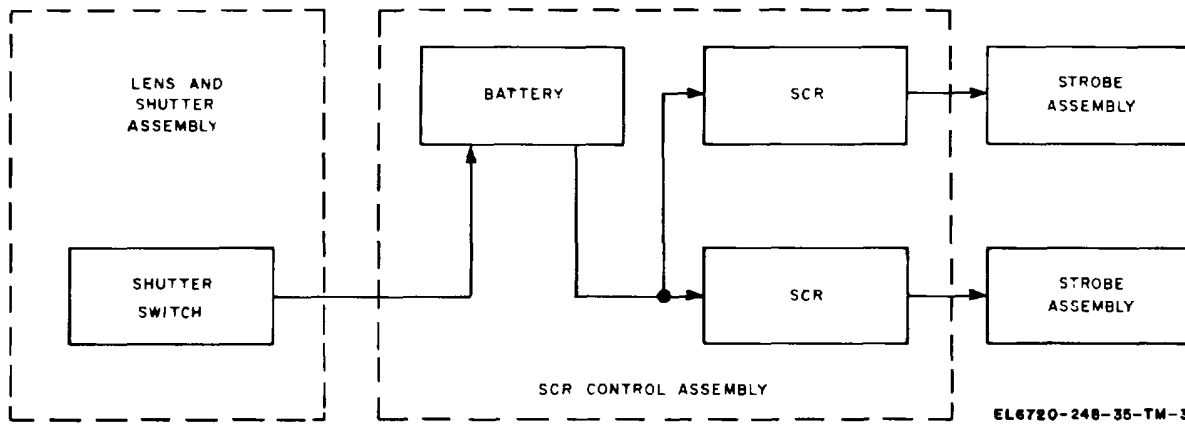

Figure 2-3. SCR control assembly, block diagram.

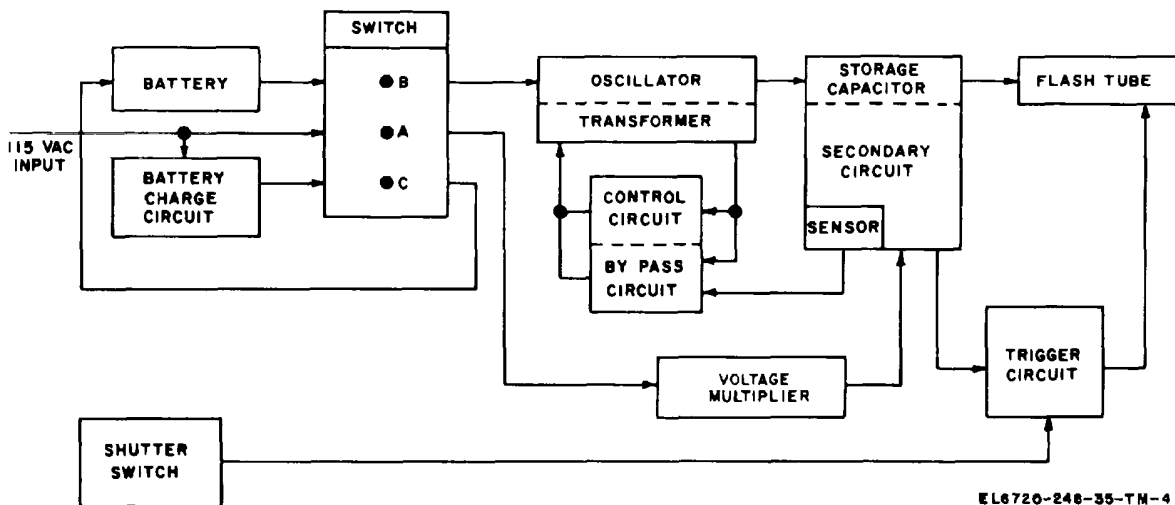

Figure 2-4. Model 600 strobe, block diagram.

circuit, which produces high voltage dc for the flash tube; a portion of the voltage is used for triggering.

c. *Control and Bypass Circuits.* The control circuit regulates the high voltage and is operated by the sensor. The oscillator circuitry is in the idle (standby) mode when the circuit is first activated, immediately after flash, and when oscillator cutoff is reached. In this mode the standby circuit bypasses the control circuit and oscillator output is low. The sensor allows the control circuit to function, which switches operation to the power mode. The power mode produces high voltage which is accumulated in the storage capacitor and the voltage builds up until a predetermined level is reached. The selected level causes the sensor to fire and turn off the control circuit; the oscillator then reverts to the idle mode.

d. *Trigger Circuit.* An input from the SCR control (which is actuated by the shutter switch) operates the trigger circuit in each strobe assembly. The drop in high voltage causes the sensor to turn the oscillator on again in the power mode, to recharge the storage capacitor.

e. *Battery Charging.* With the switch in the charge position, the battery is connected across the battery charger and requires only application of 115 vac input for operation. A taper charge is produced and monitoring is not required.

f. *Ac Operation.* The oscillator, control, and bypass circuits are not used. The ac line voltage is applied to a voltage multiplier circuit which furnishes high voltage dc to the flash tube. The trigger circuit is operative as before, but not the sensor.

2-8. Model 700 Strobe, Block Diagram Description.

(fig. 2-5)

a. *General.* The model 700 strobe operates on battery pack, ac line voltage, or battery pack and line voltage simultaneously. Operating power is determined by ON-OFF position and ac power cord use as follows:

(1) If switch is ON and power cord is not connected, strobe is operating from battery pack only.

(2) If switch is OFF and power cord is connected to 115-volt ac line, strobe is operating from ac line voltage and battery pack is being charged.

(3) If switch is ON and power cord is connected to 115-volt ac line, strobe is operating from both battery and ac line voltage. The power supply merely contains rectifiers for battery charging and high voltage dc. Battery operation uses the oscillator circuit to convert battery voltage to high voltage dc. Ac operation does not use the oscillator, but derives high voltage from the ac cord transformer which is rectified and applied direct to the storage capacitor. The battery charger is contained in the ac power cord and charges the battery any time the cord is connected.

b. *Battery Operation.* Placing the ON-OFF switch in the ON position energizes the oscillator circuit. The oscillator, in conjunction with its associated transformer, produces high voltage dc to the storage capacitor and low voltage dc for triggering.

c. *Control and Bypass Circuits.* The control circuit regulates the high voltage and is operated by the sensor. The oscillator circuitry is in the idle (standby) mode when the circuit is first activated, immediately after flash, and when oscillator cutoff is reached. In this mode the standby circuit bypasses the control circuit and oscillator output is low. The sensor allows the control circuit to function, which switches operation to the power mode. The power mode produces high voltage which is accumulated in the storage capacitor and the voltage builds up until a predetermined level is reached. The

selected level causes the sensor to fire and turn off the control circuit; the oscillator then reverts to the idle mode.

d. *Trigger- Circuit.* An input from the SCR control (which is actuated by the shutter switch) operates the trigger circuit in each strobe assembly. The drop in high voltage causes the sensor to turn the oscillator on again in the power mode, to recharge the storage capacitor.

e. *Battery Charging.* Battery charging circuits are self-contained in the ac power cord. Connecting the power to a wall receptacle and to the strobe automatically places the battery pack on charge. The 11 vac from the power cord transformer is converted to dc in the strobe and applied directly to the battery pack.

f. *Ac Operation.* The oscillator, control, and bypass circuits are not used. A high-voltage dc (approximately 500 volts) is obtained from the power cord transformer and is applied to the secondary storage capacitor circuit direct; the 6N-OFF switch remains in the OFF position.

g. *Combined Ac/Battery Operation.* This operating condition combines the circuit functions of e and f above. Normally, the strobe will be operating on ac and the oscillator will remain in the idle mode. The battery pack will be charging, but only in conditions of low line voltage would the batteries and oscillator deliver storage capacitor power.

2-9. External Battery Charger, Block Diagram Description

(fig. 2-6)

The external battery charger operates when connected to 115 vac line voltage and the timer is actuated. Actuation of the timer applies the line voltage to the primary of the transformer. The outputs from the transformer secondary is fed to the 4 rectifier circuits. The rectified voltage is then routed to the battery trays.

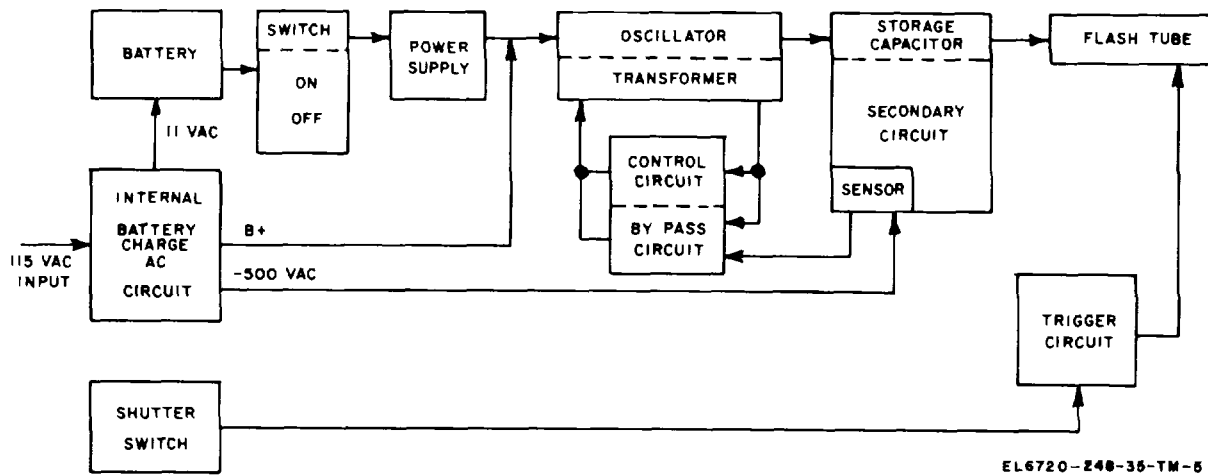

Figure 2-5. Model 700 strobe, block diagram.

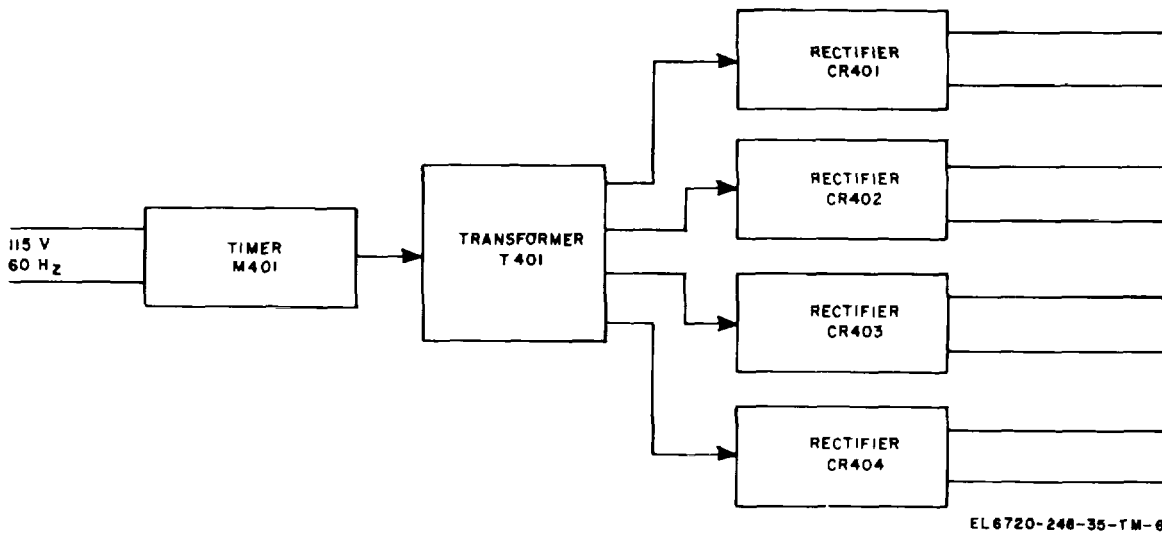

Figure 2-6. External battery charger, block diagram.

Section II. CIRCUIT ANALYSIS

2-10. SCR Control Assembly, Detailed Theory (fig. 2-7)

This circuit is an intermediate actuating device that ensures positive synchronization of both strobe assemblies. SCR anode voltage is not provided in this circuit; the polarities shown in the schematic diagram represent the voltage drop across R9 (R309 mode 700 Strobe, fig. 2-10) of the strobe assembly secondary circuit (fig. 2-8). When the shutter switch makes contact, battery BT101 is provided continuity to the gates of SCR101 and SCR102 and they are turned on. This action is the equivalent of closing jack J1 in the triggering

circuit of the strobe assembly.

2-11. Model 600 Strobe Assembly, Detailed (fig 2-8)

a. *General.* The detailed analysis of model 600 strobe assembly circuits is given in b through f below. Most of the circuits are used during the battery mode of operation; the explanation will assume this mode. Then, the remaining circuits for ac operation and battery charging will be ex-

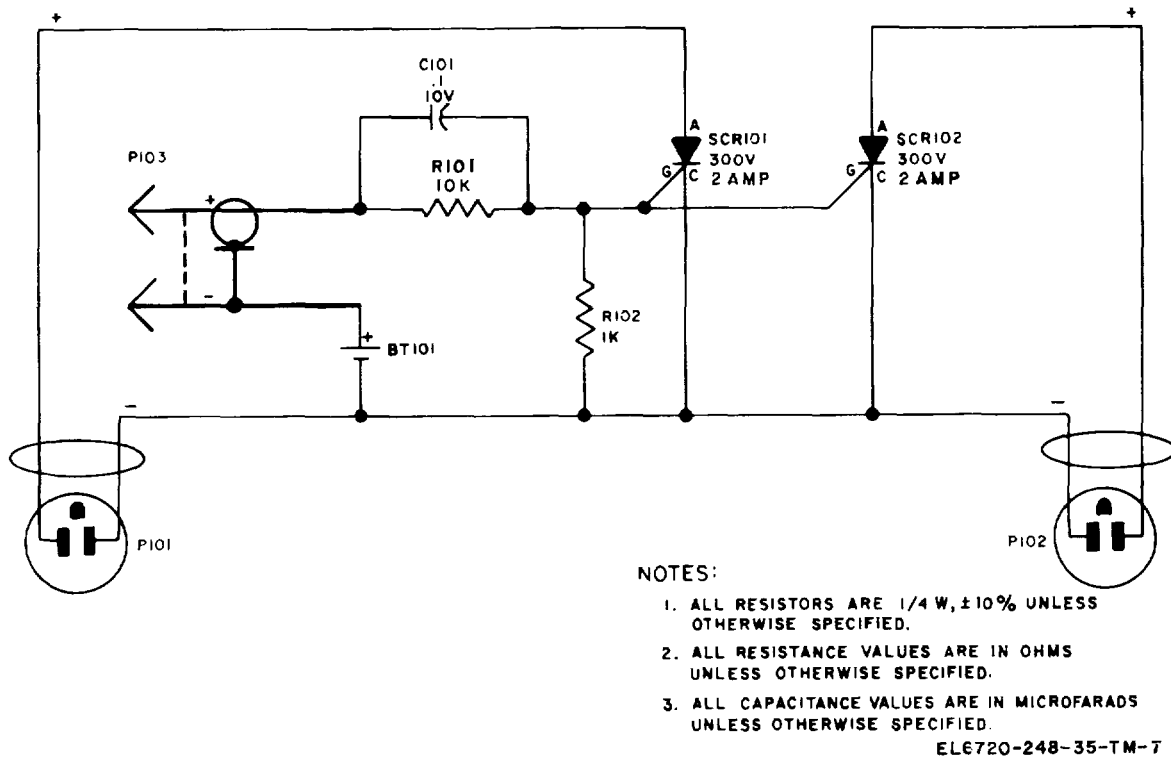

Figure 2-7. SCR control assembly, schematic diagram.

plained. Placing the selector switch in position B applies battery (BT1) voltage through contacts 1/3 and 2/4.

b. *Oscillator and Associated Circuits.* The oscillator circuit operates in either the idle mode or the power mode. In the idle mode, the bypass circuit is operative and the control circuit inoperative. Transformer T1 secondary is resonant with C2, Q1 is operating as an amplifier, and circuit efficiency and power transfer is low. In the power mode, Q1 is saturated and operates as a switch. The control circuit operates rather than the bypass circuit.

c. *Power Mode.* Power transfer of the circuit is large and efficiency is high. Figure 2-9 will be used to illustrate the power mode with respect to waveforms developed during time periods of that mode.

(1) *Time 0 (Start.)* The oscillator and transistor are off, battery current is zero, and voltage is applied across the primary of T1. A portion of this voltage is coupled through C8, R14 for a positive gate at SCR1. The voltage across T1 winding N3 forward biases the anode, so SCR1 is on (control circuit on).

(2) *Time 0-1 (Switch-On Time).* Voltage divider R2/R5 places forward bias on Q1, which starts to conduct. The current flow through Q1 and T1 winding N1 induces current in T1 secondary winding N2. The

developed voltage is applied across C2, and via rectifier CR2 to storage capacitor C3A, and a positive feedback voltage induced in T1 winding N3. With winding N3 polarized to produce positive feedback, Q1 conduction increases, and the process of conduction and feedback continues until Q1 saturates.

(3) *Time 1-2 (Core Charge Time).* Battery current increases during this period, representing the current stored in T1 core. The increase is determined by voltage applied and by T1 winding N1 resistance and inductance.

(4) *Time 2-3 (Switching Time).* Switching occurs when Q1 collector current becomes equal to Q1 beta (base current gain) times the base current. Voltage drop across Q1 increases as the voltage across T1 winding N1 decreases. This decrease is reflected back to feedback winding N3 and positive feedback decreases. This results in further voltage drop and an increase in effective impedance in Q1. There is a resultant cascading reduction of current flow in T1 winding N1. At the end of time 3, polarity reversal occurs in T1,

which reverses the polarity of the bias voltage on Q1 and Q1 is cut off.

(5) *Time 3-4 (Flyback)*. At time 3, T1 has started to reverse polarity, establishing current flow and allowing the flux in T1 core to decay. When the current in T1 secondary winding N2 has reduced to zero, the power cycle is repeated (time 4 is the same as time 0).

d. *Idle Mode*. Power mode ceases when a predetermined charge potential has been accumulated in C3A by repeated flyback cycles. The potential selected is determined by the setting of R6, which applies a portion of the voltage to sensor VR1. When this potential fires VR1, current is drawn by CR14, which produces a reverse bias on the gate of SCR1; overcoming the forward bias through C8/R14. So, SCR1 is turned off; the control circuit is bypassed, and the oscillator circuit reverts to the idle mode. Circuit C5/R5 limits Q1 base-emitter current during the positive half cycle to the amount that C5/R5 can discharge during the negative half cycle. Therefore, the constants of C5, R5 and Q1 beta determine the amount of energy transferred to T1 secondary winding N2 during oscillation in the idle mode.

e. *Voltage Multiplier Circuit*. With ac line voltage operation, the function switch makes contacts 3,5 and 4, 6. Line voltage is applied to the voltage multiplier circuit, consisting of diodes CR6, CR5, and CR3; capacitors C3A, C3B, C7, and resistors R12, R13, and R23. During the first positive half cycle, ac input terminal A is positive with respect to B and C3A and C3B charge to the value of peak line voltage. Capacitor C7 is bypassed by CR5 and CR6, but receives a small charge. During the first negative half cycle, C7 charges to twice peak line voltage. The current path is from ac input terminal B, through C3B (which adds its previous charge to the peak voltage), through CR5, and through C7 to terminal A. Resistor R13 bleeds sufficient charge from C7 to maintain 1.7 times peak line voltage on this capacitor. During the second positive half cycle, C3A is charged to 2.7 times peak line voltage, because the line voltage across terminals AB is added to the charge of 1.7 times peak line voltage on C7. The process continues for the number alternations required to fully charge storage capacitor C3A.

f. *Battery Charger Circuit*. The charging circuit consists of diode bridge CR7, CR8, CR12, and CR13, and current limiting capacitor C9A/B. The value of C9 determines the charging current at any given line voltage and frequency.

2-12. Model 700 Strobe Assembly, Detailed Theory (fig. 2-10)

a. *General*. The detailed analysis of the Model 700 strobe assembly circuits is discussed for two types of operation: battery and ac. See figure 2-10 during the following discussion.

b. *Oscillator Circuit (Battery Operation)*. When the two-position thumb switch is set to ON (up), four "Sub-C" size (welded) nickel cadmium rechargeable cells power a transistor-driven flyback oscillator. The oscillator has two modes of operation: Power Mode and Idle Mode.

(1) *Power mode*. The high-energy storage capacitor C303A is charged during the power mode. Power for the oscillator is applied from BT301 through contacts 1 and 2 of S301. The bias voltage across R302 and R303 and the transient voltage across T301 starts conduction of Q301 and SCR301. When SCR301 turns on, Q301 is forward biased. As Q301 conducts, current flows through primary winding N301 of transformer T301 which induces a regenerative feedback voltage in feedback winding N303. The positive feedback to the emitter of Q301 causes Q301 to saturate. Feedback voltage is also coupled through C308 and R314 to the gate terminal of SCR301 which keeps SCR301 turned on during the positive half of each cycle of oscillator operation. Since Q301 is saturated, the current from BT301 increases and stores energy in T301. The current from the battery increases to the point where the transistor comes out of saturation. That is, when the current flowing in the primary winding is equal to the current gain of the transistor times the base current. At this point the voltage across the transistor increases and the rate of change of current through T301 decreases, causing the voltage across T301 to drop. The voltage decrease across the transformer primary is reflected to the feedback winding N303, and Q301 turns off. Transformer T301 then reverses polarity and tries to maintain the primary current flowing. The flyback voltage increases until CR302 conducts, and holds until the current through CR302 goes to zero. This sequence of operation is repeated for many cycles until C303A charges to the cutoff voltage. A portion of the voltage across C303A is impressed across the neon (ready light) VR301. When the breakdown voltage of VR301 is reached, VR301 conducts causing current to flow through CR314 which produces a back bias voltage (cathode-to-gate) on SCR301. This back bias is sufficient to over-

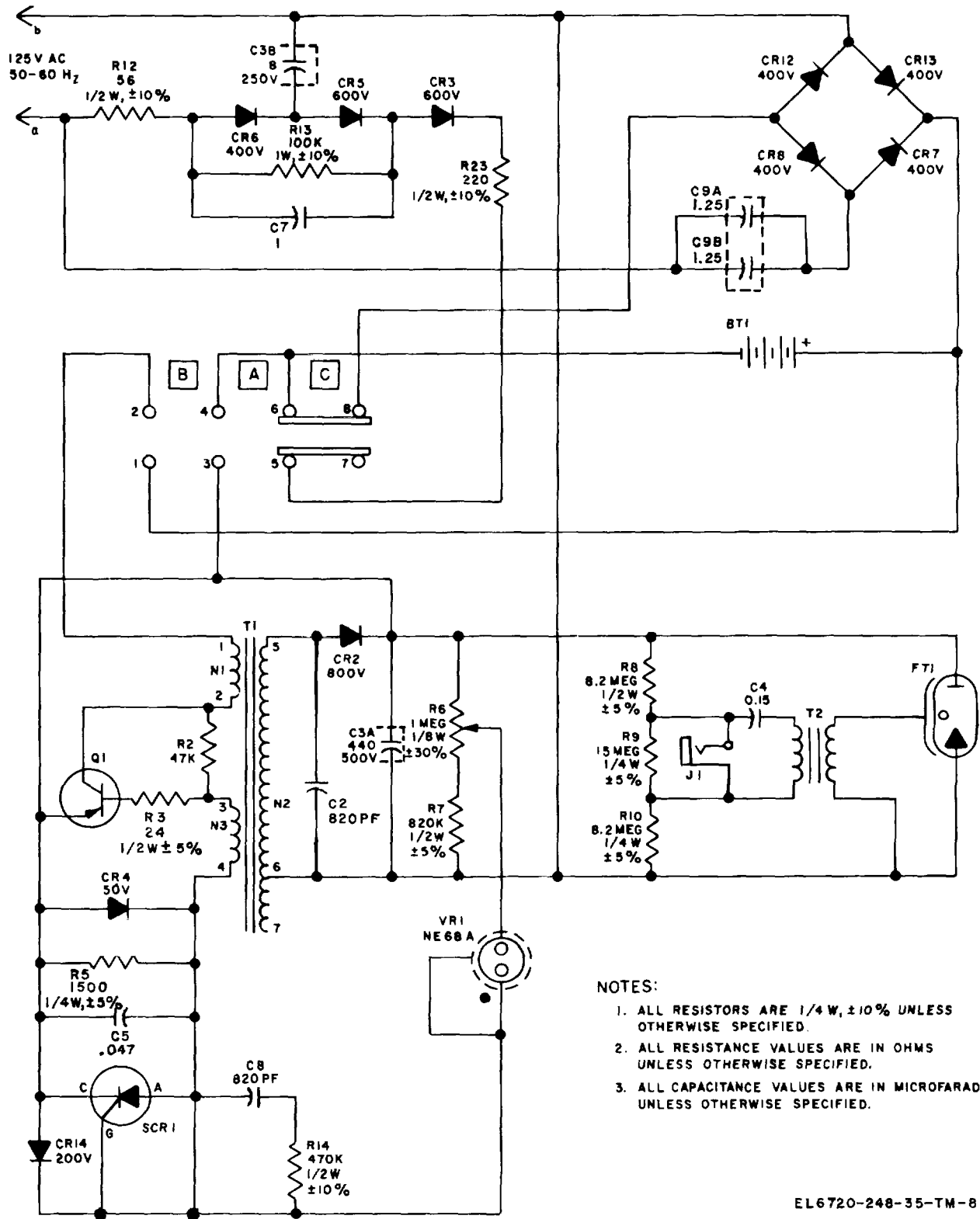

Figure 2-8. Model 600 strobe assembly, schematic diagram.

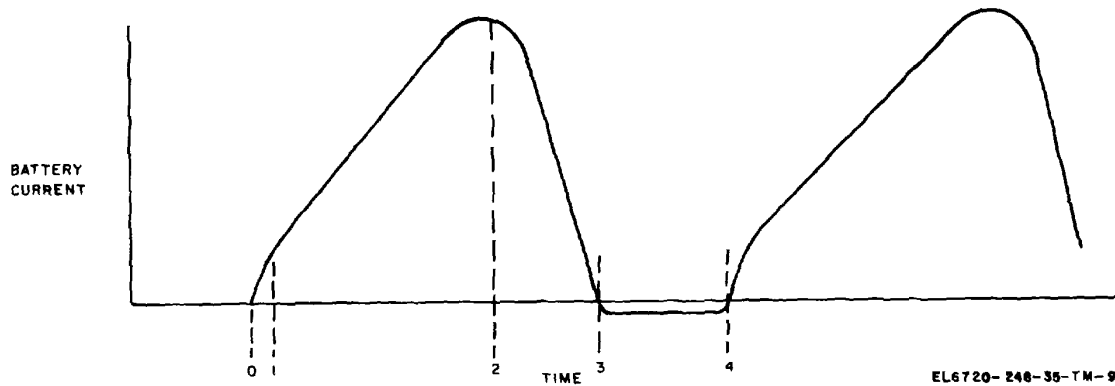

Figure 2-9. Model 600 strobe assembly power mode waveform.

come the forward bias coupled through C308 and R314 and turns off SCR301. Thus, the oscillator switches to the idle mode. Capacitor C303A charges to the cut-off voltage (435 to 490 volts depending upon the capacitance of the storage capacitor). The cut-off voltage is preset by adjusting potentiometer R306. In power mode the oscillator oscillates at a frequency between 2 and 4KHz. However, the frequency varies widely from unit to unit.

(2) *Idle mode.* The oscillator switches to the idle mode when capacitor C303A charges to the full energy or cutoff level which turns off SCR301, as previously discussed under power mode. When SCR301 turns off, the oscillator switches from a power producing circuit to a simple feedback circuit with low power capability. A portion of the feedback circuit, C305 and R305, provide selfbias for the oscillator circuit. The oscillator frequency during the idle mode is 10 to 20 KHz or approximately five times greater than the power mode. Its frequency is controlled primarily by the tuned secondary of T301. When anode voltage decreases to 80 percent of the cutoff voltage, VR301 deionizes and removes the back bias from SCR1. Thus, SCR301 turns on, and switchover from the idle mode to power mode is initiated.

c. *Trigger Circuit (Battery and Ac Operation).* Capacitor C304 charges to the voltage across R309. The charge path is through R310, T301 primary, and R308 to the supply voltage. Closing the camera shutter contacts at J301 or closing switch S303 (open flash button) completes the discharge path for C304. Thus, C304 discharges through primary of T302 and generates a trigger pulse in the secondary of T302. The trigger pulse ionizes the gas in the flashtube

FT301. The tube then fires and discharges C303A. At this time, the oscillator switches to power mode, and C303A and C304 recharge.

d. *Ac Operation Circuit.* The unit operates on ac when the wall transformer T304 is connected and S301 is in OFF position. Plugging in the wall transformer applies ac line power to pins A and B of T304. Diode CR318 serves as rectifier. Diode CR320 isolates the power input prongs (located in the strobe plug-in receptacle at the bottom of the flash head) from anode voltage. Transformer T4 operates as a step-up autotransformer. With 105 to 129 vac applied at points A and B, the voltage between points E and F will be from 280 to 350 vac, rms. When pin F of T304 is positive in respect to pin E, current flows through CR320 and CR318 to charge capacitor C303A. On the next half-cycle of ac, pin F is negative in respect to pin E; so CR318 blocks the flow of current. Thus, half-wave rectification of the stepped-up ac line is produced. Anode voltage is between 390 and 490 volts when operating on ac line.

e. *Battery Charging Circuit.* The battery charger is energized when the wall transformer is connected and S301 is in the OFF position. Wall transformer pins C and D supply approximately 11 vac to the battery charge diode CR319. Charging current is passed through the battery when pin D of T304 is positive in respect to pin C.

2-13. Lens and Shutter Assembly, Detailed Theory (figs. 2-11 and 5-1)

a. *Operating Sequence.* Depression of the shutter release lever (MP43) pivots this member against the shutter release lever springs (MP67

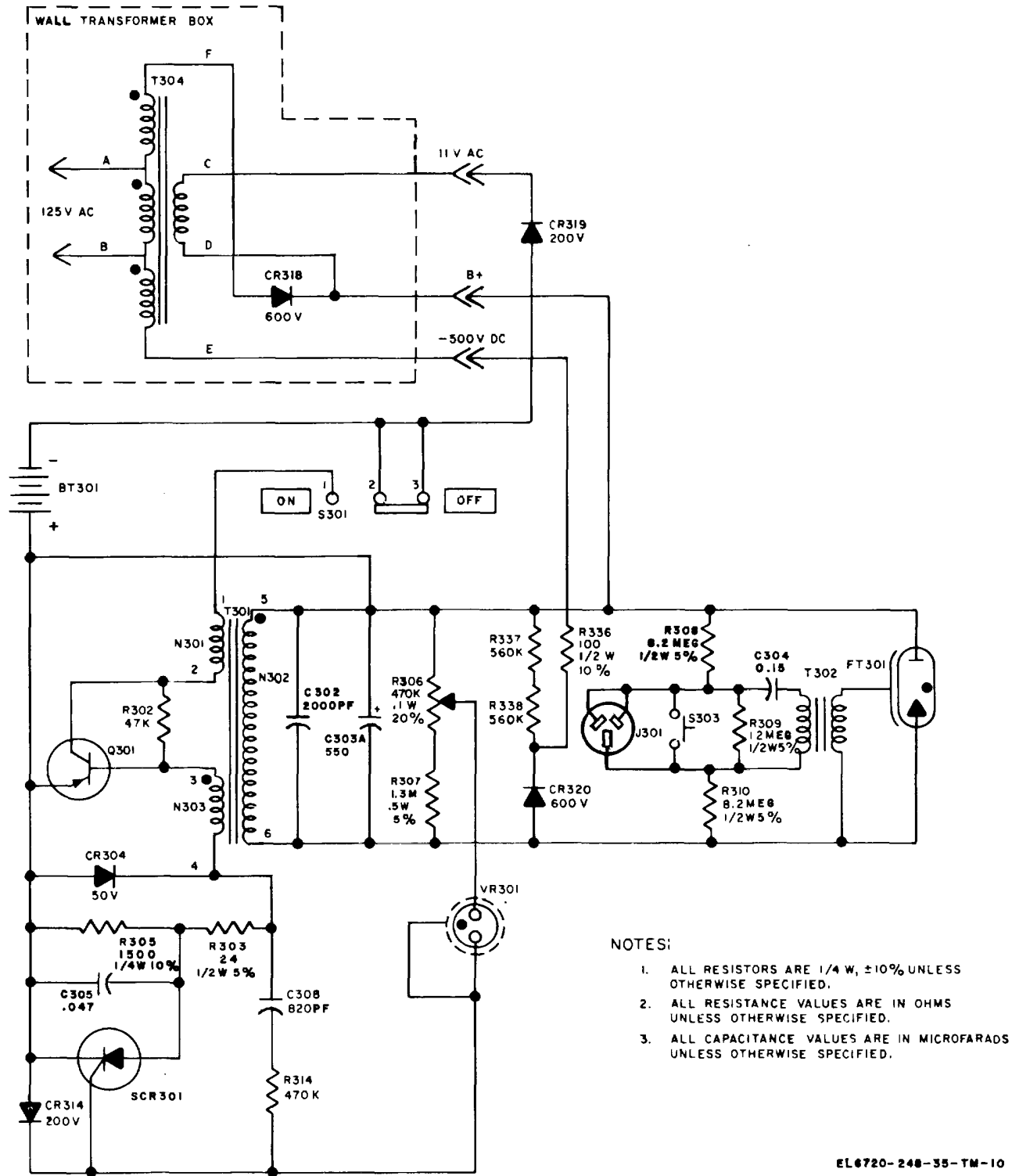

EL6720-248-35-TM-10

Figure 2-10. Model 700 strobe assembly, schematic diagram.

and MP 66) and pivots the cocking lever (MP40) against the cocking lever spring (MP63). The cocking lever (MP40) pivots down and slides over the cam of the timer mechanism assembly (A7) and allows the speed cam release lever (MP45) to disengage the speed cam lever (MP44). Further depression of the shutter release lever (MP43) disengages the locking lever (MP41) from the speed cam lever (MP44) and allows the cocking lever (MP40) to slide over the catch on the shutter actuator lever (MP38). Continued depression of the shutter release lever (MP43) pivots it far enough to disengage the cocking lever (MP40) and allow the cocking lever (MP40) to return to its normal position. When the cocking lever (MP40) returns to the normal position it engages the shutter actuator lever (MP38) and pivots the speed cam lever (MP44) in a counterclockwise direction against the tension of the cocking lever spring (MP63). Pins in the speed cam lever pivot the shutter leaves (MP35) in a clockwise direction around their hinge pins in the shutter retaining plate (MP54). This pivoting motion rotates the shutter leaves out of the lens opening, allowing light to pass for exposure of the film. The cam on the timer mechanism assembly (A7) allows the cocking lever (MP40) to complete its move to normal position. As the cocking lever (MP40) returns to normal position it releases the shutter actuator lever (MP38) and the actuator lever spring (MP61) drives the actuator lever (MP38) in a counterclockwise direction, which in turn rotates the speed cam lever (MP44) in a clockwise direction to close the shutter leaves (MP35).

b. Long Exposure. When the shutter speed adjusting ring (MP56) is set on T (time) the release lever (MP42) is pivoted to stop the cam of the timer mechanism assembly (A7) and provide a stop which will not allow the cocking lever (MP40) to return to normal position. As the shutter release lever (MP43) is depressed it actuates the cocking lever (MP40) normally and open the shutter leaves (MP35). A second depression of the shutter release lever (MP43) will

disengage the cocking lever (MP40) and allow it to return to its normal position and close the shutter leaves (MP35).

c. Flash Synchronization. Flash synchronization of the lens and shutter assembly is accomplished by a movable finger and a stationary contact, which are an integral part of the lens and shutter assembly housing (A6). As the speed cam lever (MP44) rotates in a counterclockwise direction it operates the movable finger and makes contact with the stationary contact. The closing of this contact completes the trigger circuit through the shutter cord.

d. Iris Diaphragm. Size of the iris diaphragm aperture is controlled by moving the control lever which is a part of adjusting ring (MP55). Pointer portion of the control lever indicates the aperture on the scale on indicator plate (MP48). Scale reads in the range of f/4.5 to f/22. Movement of the adjusting ring shifts the alignment of the ring in relationship to the iris diaphragm leaves. A pair of pins on each leaf are engaged with slots in the adjusting ring; the pins on each leaf being engaged in adjacent slots. Spring washer (MP72) maintains the engagement of leaves with the adjusting ring. The slot in lens and shutter assembly housing (A6) limits the movement of the control lever.

2-14. External Battery Charger, Detailed Theory (fig. 2-12)

Line voltage (115 vac) is applied to the primary of transformer T401 through the switch in timer M401. Timer switch closes when the timer is set and pilot light DS401 illuminates. The 12 vac picked off by each of the four secondary windings is rectified by the diode and resistor combination. The rectified voltage is supplied to each of four battery trays.

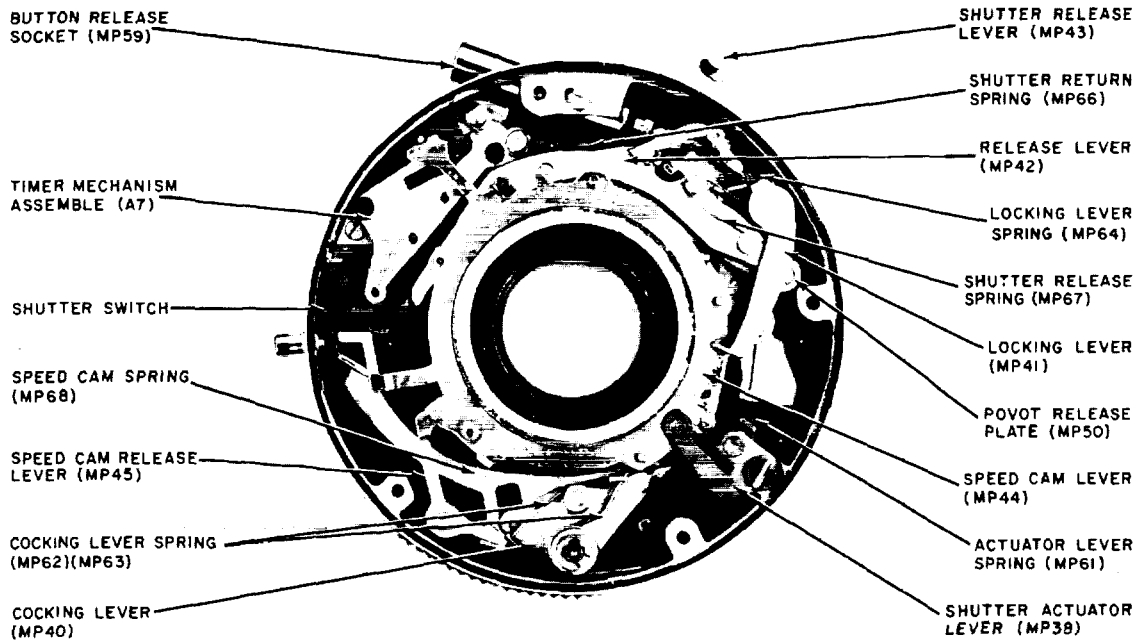

EL6720-248-35-11

Figure 2-11. Lens and shutter assembly, interior view.

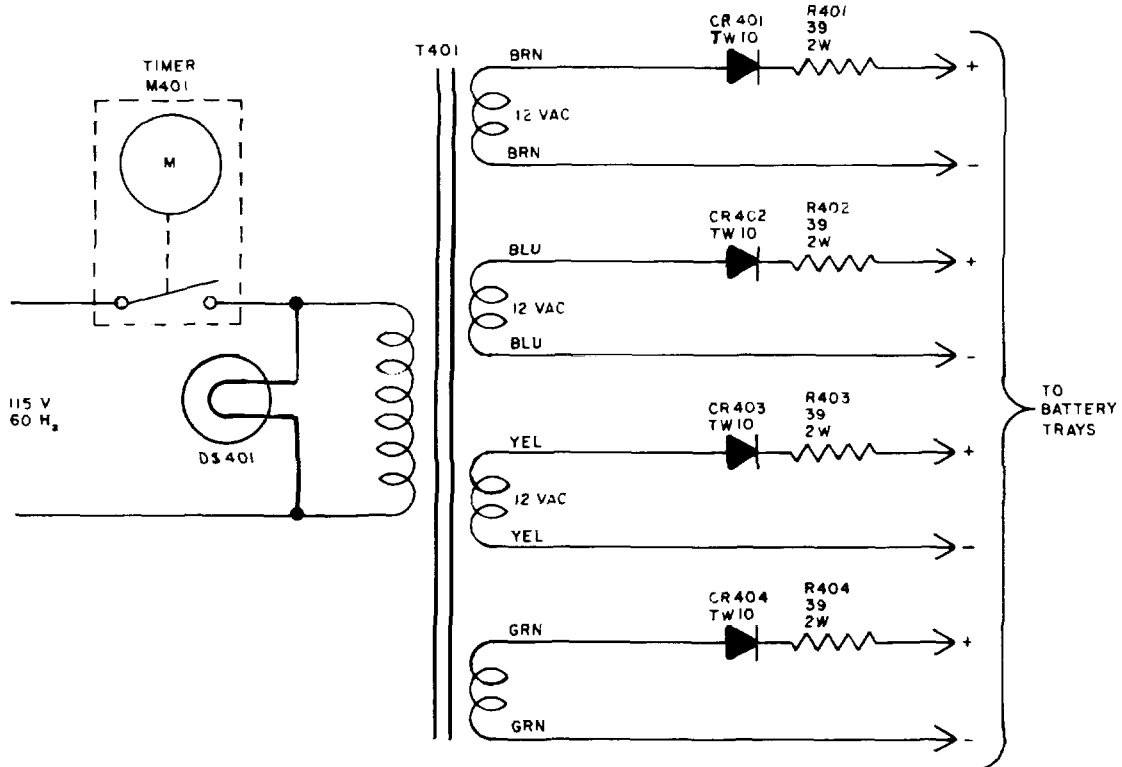

EL6720-248-35-TM-12

Figure 2-12. External battery charger, schematic diagram.

CHAPTER 3 DIRECT SUPPORT MAINTENANCE

Section I. GENERAL

3-1. Scope of Maintenance

a. Troubleshooting at the direct support level includes all the procedures outlined for operator's and organizational maintenance (TM 11-6720-248-12). The systematic troubleshooting procedure, which begins with the operational and sectionalization checks performed at the organizational level, must be completed by localizing and isolating techniques. Paragraph 3-4 describes troubleshooting procedures performed at the direct support level.

b. Troubleshooting may be performed while the equipment is operating or, if necessary, after the equipment has been removed from service. When trouble occurs, observations and measurements can be made to help determine the source of trouble. At the organizational level, troubleshooting is performed with equipment in operation (TM 11-6720-248-12). At the direct support level, troubleshooting should begin with the equipment in operation and proceed until sectionalization discloses trouble in either the lens and shutter assembly or a strobe assembly. If either of these are defective, localization and isolation is performed at a higher level. Paragraph 3-4 introduces troubleshooting

charts that will enable maintenance personnel to isolate the trouble to any major subassembly and to correct faults in all but the lens and shutter assembly or strobe assembly, which are discussed in chapters 5 and 6, respectively.

3-2. Tools, Materials, and Test Equipment Required for Direct Support Maintenance

The following tools, materials, and test equipment are required for direct support troubleshooting and repair:

a. Tools. Toolkit, Photographic Repairman TK-109/GF.

b. Materials.

- (1) Cleaning compound (FSN 7930-395-9542).
- (2) Grease, aircraft and instrument (GL) (FSN 9150-576-4262).
- (3) Lubricating oil, general purpose (LO) (FSN 9150-252-6173).

c. Test Equipment.

- (1) Multimeter TS/352.
- (2) Focusing screen.

Section II. TROUBLESHOOTING

3-3. Organization of Troubleshooting Procedures

a. General. The first step of servicing defective equipment is sectionalization. Sectionalization means tracing the fault to a specific major component. The second step, localization, means tracing the fault to the defective section or subassembly of the major component. The third step, isolation, means tracing the fault to the defective part. Some faults, such as poor shutter response or binding of mechanical components, can be isolated by sight, touch, or hearing. The majority of faults, however, must be isolated by detailed electrical, mechanical, and optical checks.

b. Sectionalization. Sectionalization is performed by operating the equipment (TM 11-6720-248-12). Examination of a processed print will sometimes reveal faults that are not otherwise apparent.

c. Localization. If the cause of the trouble is not located during the sectionalization procedure (b above), refer to the troubleshooting charts in paragraph 3-4 (charts a, b, and c). These charts will aid in localizing and isolating faults. For the strobe assemblies, this chapter does not go beyond

sectionalization. After a fault is isolated to a strobe assembly, localization and isolation is performed using the procedures in chapter 6.

d. *Isolating Electrical Faults (SCR Control Assembly and External Battery Charger).* To isolate an electrical fault, it is usually necessary to trace the circuit from point to point after the trouble has been localized; use the schematic diagrams (figs. 2-7 and 2-12). Before measuring the resistance of a component, disconnect the component from any parallel circuits that will affect the resistance measurement. Use the resistor and capacitor color-code markings (fig. 6-13) to determine the value of the resistors and capacitors. The possibility

of intermittent faults should not be overlooked. This trouble may be located by tapping or jarring the equipment. Prior to removing a suspected defective component perform a continuity check of wiring leading to the component.

3-4. Troubleshooting Charts

The following troubleshooting charts are supplied as an aid to locating troubles in the camera set. The charts list the symptoms, probable trouble, and checks and corrective measures. The troubleshooting chart for the strobe assemblies is in chapter 6.

a. *Camera Assembly Troubleshooting Chart.*

Item No.	Trouble symptom	Probable trouble	Checks and corrective measures
1	Titleboard holder assembly will not hold titleboard.	Titleboard holder assembly (6, fig. 3-1) damaged or worn.	Replace titleboard holder assembly (para 3-7).
2	Titleboard holder assembly will not secure to horizontal positioning bar.	Horizontal positioning bar (2, fig. 3-1) damaged or worn.	Replace titleboard holder assembly (para 3-7) or horizontal positioning bar (para 3-7).
3	Horizontal positioning bar cannot be secured to socket in camera housing.	Horizontal positioning bar (2, fig. 3-1) damaged or bar latch assembly (31, fig. 3-2) damaged or worn.	Replace horizontal positioning bar (para 3-7) or bar latch assembly (para 3-7).
4	Camera back will not rotate -----	Jammed at pivot (25, fig. 3-2) or shutter latch assembly jammed (7, fig. 3-2).	Check parts 7, 11, 12, 27 through 30, for free play. Check alignment of housing adapter (21) and main pivot pin (25), all fig. 3-2.
5	Print completely white -----	Light leaks. Damaged polaroid back (16) or lens and shutter assembly (5).	Check operation of shutter. If normal, replace camera back (para 3-10).
6	Print completely dark-----	Lens and shutter assembly (5, fig. 3-2).	Replace lens and shutter assembly(para 3-10).
7	Image or print is not clear (out of focus).	Focal length incorrect -----	Adjust focus (para. 3-12).
8	Shutter release mechanism will not reset.	Double exposure prevention device(shutter latch assembly) or associated parts jammed. Lens and shutter assembly (5, fig. 3-2).	Check for damage or friction at 7, fig. 3-2. Replace lens and shutter assembly (5, fig. 3-2).
9	Shutter will not trip -----	Misaligned release shaft (13), or defective lens and shutter assembly (5, fig. 3-2).	Check alignment of shaft before replacing lens and shutter assembly. Also check operation of shutter latch assembly (7, fig. 3-2).
10	Image vignette or incorrect centering --	Stereoscopic attachment damaged (1, fig. 3-2).	Replace stereoscopic attachment (para 3-7).
11	Strobe assemblies do not flash -----	a. Isolate if only one fails ----- b. If both fail, probably caused by SCR control or lens and shutter assembly. It is assumed	a. Exchange strobe assemblies (4) on support arm assembly (3)- all fig. 3-1. Or, exchange shutter cords (12, fig. 3-1). b. Operate strobe assemblies manually with jumper replacing flash cord (12, fig. 3-1). If opera-

Item No.	Trouble symptom	Probable trouble	Checks and corrective measures
		that organizational level tests have been performed and that strobe batteries have been checked.	tional, then check flash cord continuity (11, fig. 3-1) and flash cord jack on lens and shutter assembly (5, fig. 3-2). If lens and shutter assembly is the cause, refer repair to next higher level of maintenance. If SCR control at fault, refer to b below.

b. SCR Control Assembly Troubleshooting Chart.

Item No.	Trouble symptom	Probable trouble	Checks and corrective measures
1	Both strobe assemblies fail to flash--	a. Defective BT101 ----- b. Defective P103 or bad connections	a. Replace BT101. b. Replace P103 or repair connections.
2	One strobe assembly -----	c. BT101 reversed----- a. SCR101 or SCR102 defective -----	c. Install correctly. Exchange flash cords at strobe assemblies. If trouble transfers to other strobe assembly, strobe assemblies are alright; make continuity checks and test SCR and associated parts in each circuit.
3	Intermittent operation -----	b. P101 or P102 defective----- c. W101 or W102 defective ----- a. Intermittent battery contact or low voltage b. Any connection may be intermittent. c. Trouble external to SCR control.	a. Clean and adjust battery and check battery. b. Check solder terminals and condition of all cables. c. Unlikely affecting both strobe assemblies unless operation is from line voltage.

c. External Battery Charger Troubleshooting Chart.

Item No.	Trouble symptom	Probable trouble	Checks and corrective measures
1	All four trays fail to charge but pilot lamp is lit.	Defective transformer T401 -----	Replace T401.
2	One tray fails to charge -----	a. Diode or resistor within circuit to faulty tray defective. b. Defective T401.	Check for 12 ± 1 vac at T401 secondary leads of bad circuit. If voltage is absent replace T401. If voltage is present check and replace associated diode and/or resistor.
3	All four trays fail to charge and pilot lamp is not lit.	Defective timer switch -----	Replace timer M401.
4	Timer does not operate or times wrong.	Defective M401 -----	Replace M401.
5	Charger operates but pilot lamp is not lit.	Defective DS401 -----	Replace DS401.

Section III. REPAIR

3-5. Scope of Direct Support Repair and Adjustment Procedures

Paragraphs 3-6 through 3-18 contain instructions covering direct support repair and adjustment of the camera set assemblies. Repair of the lens and shutter assembly is given in paragraphs 5-1 through 5-8; repair of the strobe assembly is given in paragraphs 6-5 through 6-7.

- a. General parts replacement techniques (para 3-6).
- b. Disassembly of camera set (para 3-7).
- c. Reassembly of camera set (para 3-8).
- d. Adjustment of camera set (para 3-9).
- e. Disassembly of camera assembly (para 3-10).
- f. Reassembly of camera assembly (para 3-11).
- g. Focus adjustment (para 3-12).
- h. Disassembly of tripod (para 3-13).
- i. Reassembly of tripod (para 3-14).
- j. Disassembly of support arm assembly (para 3-15).
- k. Reassembly of support arm assembly (para 3-16).
- l. Disassembly of external battery charger (para 3-17).
- h. Reassembly of external battery charger (para 3-18).

3-6. General Parts Replacement Techniques

a. *Partial Disassembly.* Repair of the camera set at the direct support level consists of replacing worn or damaged parts. For repair purposes, complete disassembly is not always necessary; disassemble only as far as necessary to replace worn and damaged parts. When an assembly is disassembled, check all parts for wear and damage. If inspection of a part indicates that it is worn or damaged, replace it.

b. *Marking.* During disassembly, tag all terminals and wiring to insure correct connections during reassembly (para 3-15).

3-7. Disassembly of Camera Set

(fig. 3-1)

Disassemble the camera set as follows:

- a. Disconnect the power cord (10) from the flash unit assemblies (4) and the power source.
- b. Remove the titleboard (6) from the horizontal positioning bar assembly (2).
- c. Rotate the horizontal positioning bar assembly (2) clockwise and withdraw it from the camera assembly (1).
- d. Loosen the thumbscrew on the stereoscope (5) and remove the stereoscope from the camera assembly (1).
- e. Disconnect the shutter cord (11) from the camera assembly (1).
- f. Disconnect flash cords (12) from unit assemblies (4).
- g. Remove the flash unit assemblies (4) from the support arm assembly (3).
- h. Loosen the two thumbscrews attaching the support arm assembly (3) and remove the support arm assembly from the camera assembly (1).
- i. Loosen the socket head screw on the camera assembly (1) and remove the camera assembly from the tripod (7). (See: 34, fig. 3-2.)
- j. If attached, remove cap and filter assembly (9) from camera assembly (1) and place in storage compartment (see inset) of camera assembly back.

CAUTION

The tripod inner tube is spring-loaded. Rest your hand over the tube before operating the telescope clamp screw.

3-8. Reassembly of Camera Set

(fig. 3-1)

Reassemble the camera set as follows:

- a. Set up the tripod (TM 11-6720-248-12).
- b. Attach camera assembly (1) to tripod (7) and tighten the socket head screw on the camera assembly (34, fig. 3-2).
- c. Place support arm assembly (3) on camera assembly (1) and secure with the two thumbscrews.
- d. Attach the two flash unit assemblies (4, 4A) to the support arm assembly (3).
- e. Connect flash cords (12) to flash unit assemblies (4).

- f. Connect shutter cord assembly (11) to camera assembly (1); at lens and shutter assembly.
- g. Attach cap and filter assembly (9) to camera assembly (1); at lens and shutter assembly.
- h. Attach stereoscope (5) to camera assembly (1), and tighten thumbscrew.
- i. Insert horizontal positioning bar assembly (2) in camera assembly (1), and rotate counterclockwise to lock.

- j. Attach the titleboard (6) to the horizontal positioning bar assembly (2).
- k. Connect power cord (10, 100A) to flash unit assemblies (4) and to power source.

3-9. Adjustment of Camera Set

Operational adjustments only (TM 11-6720-248-19).

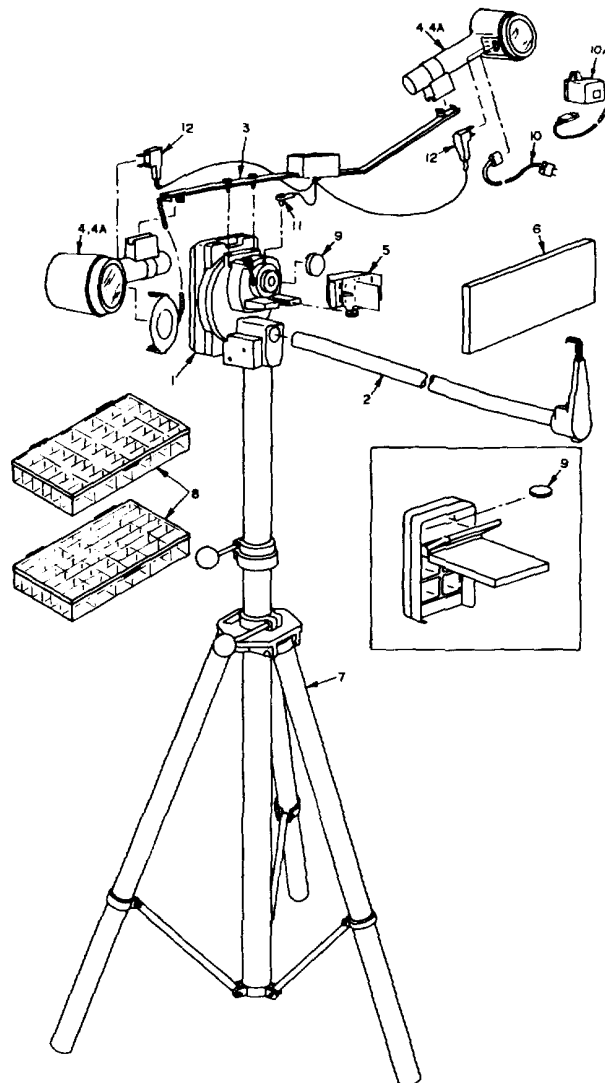

EL 6720-248-35-TM-13

- | | | | |
|----|---|-----|-----------------------------|
| 1 | Camera assembly (MP2) | 7 | Tripod assembly (A19) |
| 2 | Horizontal positioning bar assembly (A34) | 8 | Character set (MP207) |
| 3 | Support arm assembly (A25) | 9 | Cap and filter (A37) |
| 4 | Strobe assembly model 600 (A29) | 10 | Power cord model 600 (W104) |
| 4A | Strobe assembly model 700 (A40) | 10A | Power cord model 700 (W301) |
| 5 | Stereoscope (MP6) | 11 | Shutter cord (W103) |
| 6 | Titleboard (MP1) | 12 | Flash cord (W101, W102) |

Figure 3-1. Camera set, exploded view.

3-10. Disassembly of Camera Assembly

(fig. 3-2)

Disassemble the camera assembly as follows:

a. Loosen the cap screw (34) and remove the camera assembly from the tripod.

b. Open the two doors of the back assembly (16). Remove the four screws (17) and the two adaptor washers (18), and remove the back assembly.

c. Loosen two setscrews (4) in adjustable cell (3) and remove adjustable cell (3) from main support casting (33).

d. Remove retaining ring (22) and washer (23) from main pivot pin (25) in the housing adapter (21).

e. Separate main support casting (33) and housing adapter (21). Remove nylon washer (24) from main pivot pin (25).

f. Disassembly of adjustable cell (3).

(1) Loosen screw (8) and remove shutter latch assembly (7) and washer (10). Remove roll pin (9) from shutter latch assembly (7). Remove spring (12) from lever and shaft (11). Remove lever and shaft (11).

(2) Remove retaining ring (15) from release shaft (13) and remove release shaft (13) from adjustable cell (3) with actuate button (14) intact. (The actuate button (14) is press fit on the release shaft.)

(3) Remove lens and shutter assembly (5) by removing retaining nut (6) with spanner wrench.

g. Disassembly of main support casting (33).

(1) Remove screw (28) and washer (29). Remove lever assembly (27) and spring (30).

(2) Remove two screws (32) and latch assembly (31).

h. Disassembly of housing adapter (21).

(1) Loosen setscrew (26) and remove main pivot pin (25).

(2) Remove screw (20) and spring latch (19).

i. Disassembly of back assembly (16) (fig. 3-3).

(1) Remove two hinge plugs (6) and drive out hinge pin (7). Remove door assembly (1), divider frame (10) and rear cover (2).

(2) Remove rivets (3) and (5) and rear cover spider (4) from rear cover (2).

(3) Remove three rivets (9) and door hinge (8) from divider frame (10).

j. Disassembly of door assembly (1) (fig. 3-4).

(1) Remove four rivets (13), rear door spider (3) and roll latch (17) from the rear door (15).

(2) Remove three rivets (4) and door hinge (16).

(3) Remove two spread roll pivots (11, fig. 3-5) and frame roller support assembly from rear door spider (3).

(4) Remove two exit door pivot studs (11), exit door pivot spring (12) and exit door assembly (10). Remove three rivets (9) and three rivets (14) to free exit guide bar (8) and exit cover frame (7).

(5) Remove two rivets (5) and two roll frame springs (6).

(6) Remove two rivets (2) and door spring (1).

k. Disassembly of frame roller support assembly (A39) (fig. 3-5).

(1) Removal of the two spread roll pivots (11) in j (3) above releases the following parts: the two spread roll springs (1), left front roll support (2), right front roll support (3), front roller (6), rear roller (7), two roller bushings (4) and two roller bushings (5).

(2) Remove three screws (18), slide block cover (17) and slide block link (19).

(3) Slide out camera body shaft (15) and remove two locating springs (14) and edge control bar assembly (13).

(4) Remove four rivets (8) and two slide plates (9) from roller frame support (10). This frees the slide block (16) and slide block spring (12).

3-11. Reassembly of Camera Assembly

(fig. 3-2)

Reassemble the camera assembly as follows:

a. Reassembly of frame roller support assembly (A39) (fig. 3-5).

(1) Hook slide block spring (12) to slide block (16) and roller frame support (10); secure with two slide plates (9) and four rivets (8).

(2) Position the two locating springs (14), and the edge control bar assembly (13) on the

slide block (16) and secure by sliding the camera body shaft (15) through all three.

(3) Secure slide block cover (17) and slide block link (19) with three screws (18).

b. Reassembly of door assembly (1, fig. 3-5) (fig. 3-4).

(1) Secure door spring (1) and the two roll frame springs (6) to rear door spider (3) with four rivets (2) and (5).

(2) Secure exit guide bar (8) to exit cover frame (7) with three rivets (9). Secure exit cover frame (7) to rear door spider (3) with three rivets (14).

(3) Attach exit door assembly (10) and exit door pivot spring (12) to exit cover frame (7) with two exit door pivot studs (11). See figure 3-5 for (4), (5), and (6) below.

(4) Place two roller bushings (4) on front roller (6) and two roller bushings (5) on rear roller (7). Position rear roller (7) in roller cradle on roller frame support (10).

(5) Put right and left front roll supports (2) and (3) on front roller (6); then position roller and supports on the roller frame support (10).

(6) Press spread roller springs into position between right and left front roller supports (2) and (3) and roller frame support (10).

(7) Secure frame roller support assembly to rear door spider (3) with two spread roller pivots (11, fig. 3-5).

(8) Secure door hinge (16) to rear door spider (3) with three rivets (4).

(9) Secure roll latch (17) and rear door spider (3) to the rear door (15) with four rivets (13); insure slide block link (19, fig. 3-5) is under rear door spider (3, fig. 3-4) catch prior to riveting.

c. Reassembly of back door assembly (16, fig. 3-2) (fig. 3-3).

(1) Secure door hinge (8) to divider frame (10) with three rivets (9).

(2) Secure rear cover spider (4) to rear cover (2) with two rivets (3) and (5).

(3) Connect door assembly (1), rear cover (2) and divider frame (10) with hinge pin (7). Secure hinge pin (7) with hinge plugs (6).

d. Reassembly of housing adapter (21).

(1) Attach spring latch (19) with screw (20).

(2) Insert main pivot pin (25) and rotate it to accept setscrew (26). (The flatted end of this

pin shall be parallel with top and bottom surfaces of housing adapter. Tighten setscrew (26). Install nylon washer (24) on main pivot pin (25).

e. Reassembly of main support casting (33).

(1) Place spring (30) over the boss in the casting. The loop of the spring shall be above the legs of the spring and the long leg goes to the left.

(2) The bearing of the nylon roller in the lever assembly (27) has a turned shoulder. Fit this shoulder over the leg of the spring and press the lever assembly into place so that its mounting hole lines up with the tapped hole in the casting. Hold in this position and secure lever assembly (27) with washer (29) and screw (28). (Note that (29) is a step washer and the shoulder is a bearing for the mounting hole.)

(3) Attach latch assembly (31) with two screws (32).

f. Reassembly of adjustable cell (3).

(1) Attach lens and shutter assembly (5) with retaining nut (6) and tighten with spanner wrench.

(2) Press actuate button (14) on release shaft (13). Install release shaft (13) and secure with retaining ring (15).

(3) Install lever and shaft (11) and spring (12).

(4) Insert roll pin (9) into shutter latch assembly (7). Attach shutter latch assembly (7) to shaft of lever and shaft (11), so that shutter latch assembly (11) rests against barrel of lens and shutter assembly (5) while lever and shaft (11) is horizontal. (Spring (12) will be under tension.) Secure the assembly by tightening screw (8).

g. Join main support casting (33) and housing adapter (21). Place washer (23) on the main pivot pin (25). Retain the assembly with retaining ring (22). (The concave face of the retaining ring faces the casting.) After installation of retaining ring (22), rotate it so that its open ends face toward center.

h. Join adjustable cell (3) and main support casting (33) as follows:

(1) Hold shutter latch assembly (7) down, so that lever and shaft (11) is certain to pass below main pivot pin (25).

(2) When adjustable cell (3) is seated properly, rotate housing adapter (21) *clockwise* and watch for correct movement of shutter latch assembly (7). Check that shutter is latched when

the actuate button is operated and released when the adapter is rotated.

(3) Secure adjustable cell (3) to main support casting (33) by tightening the two setscrews (4).

i. Attach back assembly (16). Open the two doors of back assembly (16) and attach the assembly to housing adapter (21) with four screws (17) and two adapter washers (18).

j. Reassemble the camera set (TM 11-6720-248-12).

3-12. Focus Adjustment

(fig. 3-2)

Adjust focus as follows:

a. With camera set completely assembled (TM 11-6720-248-12), place approximately eight letters on the titleboard.

b. Remove density filter (9, fig. 3-1) and loosen the two setscrews (4) on the adjustable cell (3).

c. Set shutter speed to B, iris diaphragm control lever to 4.5, and place a focusing screen (ground glass) in back of camera on film plane (dull side of ground glass toward lens).

d. Trip the shutter and view the letters on the titleboard through the focusing screen (ground glass) from the back of the camera.

(1) Move the adjustable cell (3) back or forward on the main support casting (33) to the position where the letters on the titleboard are the sharpest and clearest (in focus).

(2) Tighten the two setscrews (4) at the in focus position.

c. Remove focusing screen from back of camera and replace the density filter.

3-13. Disassembly of Tripod

(fig. 3-6)

a. Set up the tripod (TM 11-6720-248-12).

b. Place hand over inner tube (2) and release telescope clamp (14) with knob (17); meanwhile applying hand pressure downward to control spring action. Let inner tube rise to full height; then withdraw inner tube from outer tube (18) and telescope clamp (14).

c. Withdraw counterbalance assembly (12) from outer tube (18).

d. Loosen hinge clamp knob assembly (22).

Remove three screws (24) and pull outer tube (18) away from hinge plug (25) and out through legs hinge (20).

e. Figure 3-6 illustrates one leg and leg link assembly to represent all three. The following instructions apply to any one of the three:

(1) Drive out the hinge stud (23). Remove acorn nut (32) and screw (30) from leg clamp (31). Release leg link (28) from leg clamp.

(2) Remove acorn nut (27) and screw (26) from hinge plug (25) to free leg link (28).

(3) Pry leg clamp (31) open slightly and slide from leg assembly (29).

f. To disassemble the counterbalance assembly-

(1) Remove two hex nuts (11) from spring anchor assembly (10); releasing torsion springs on spool assemblies (3).

(2) Pull off the two retaining rings (7) from each pin (8), and drive the pin out of yoke and rod assembly (9), releasing torsion spring and spool assemblies (3). Fiber washers (4) fall free and counterbalance spool (6) can be pushed out of the torsion spring (5).

g. To remove the telescope clamp (14) from inner tube (2), loosen screw (16) and pry open the split-ring portion of the clamp so that the clamp will pass over the ridge at the end of the tube.

3-14. Reassembly of Tripod

(fig. 3-6)

a. Attach leg clamp (31) to leg assembly (29) and locate leg clamp at dimple in leg tube. Repeat for remaining two legs.

b. Attach leg link (28) to leg clamp (31) with screw (30) and acorn nut (32). Repeat for remaining two legs.

c. Attach leg assembly (29) to legs hinge (20) with hinge stud (23). Repeat for remaining two legs.

d. Join leg link (28) to hinge plug (25) with screw (26) and acorn nut (27). Repeat for remaining two leg links.

e. Arrange this part of the assembly as it would stand when unfolded.

f. Assemble each torsion spring and spool assembly (3) with counterbalance spool (6), torsion spring (5), and two fiber washers (4). Hold this assembly in alignment and attach to yoke and

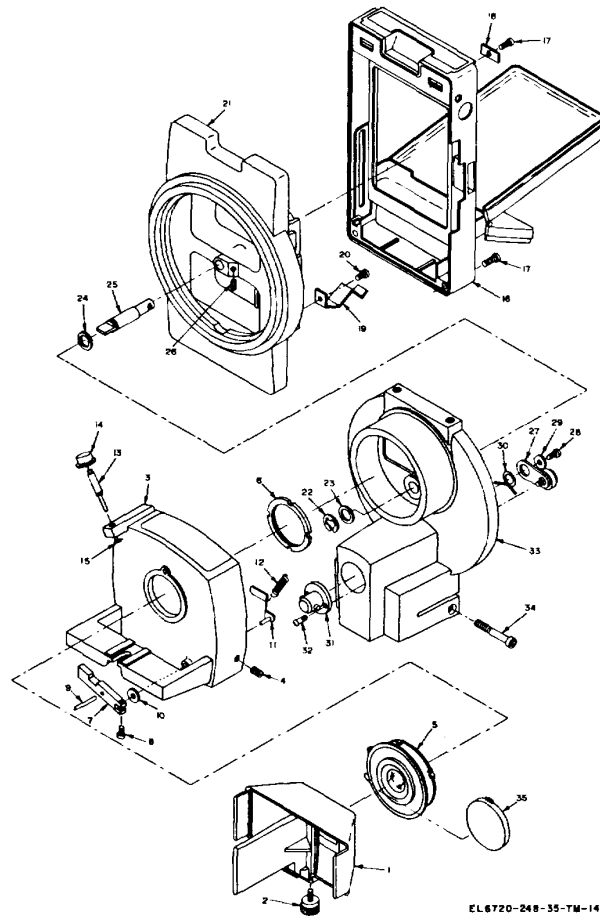

- | | | | |
|----|------------------------------------|----|-----------------------------|
| 1 | Stereoscopic adapter (MP6) | 19 | Spring latch (MP82) |
| 2 | Thumbscrew (MP7) | 20 | Screw (MP83) |
| 3 | Adjustable cell (MP22) | 21 | Housing adapter (MP81) |
| 4 | Setscrew (MP12) | 22 | Retaining ring (MP74) |
| 5 | Lens and shutter assembly (A5) | 23 | Washer (MP75) |
| 6 | Retaining nut (MP29) | 24 | Nylon washer (MP76) |
| 7 | Shutter latch (with item 8) (MP19) | 25 | Main pivot pin (MP84) |
| 8 | Screw (MNP18) | 26 | Setscrew (MP85) |
| 9 | Roll pin (MP20) | 27 | Lever assembly (A18) |
| 10 | Washer (MP27) | 28 | Screw (MP91) |
| 11 | Lever and shaft assembly (A4) | 29 | Step washer (MP98) |
| 12 | Spring (MP26) | 30 | Detent spring (MP97) |
| 13 | Release shaft (MP16) | 31 | Latch assembly (A17) |
| 14 | Actuate button (MP15) | 32 | Screw (MP88) |
| 15 | Retaining ring (MP14) | 33 | Main support casting (MP95) |
| 16 | Back assembly (A9) | 34 | Capscrew (MP96) |
| 17 | Screw (MP78) | 35 | Lens cap (MP 21) |
| 18 | Adapter washer (MP79) | | |

Figure 3-2. Camera assembly, exploded view.

rod assembly (9) with pin (8). Secure with retaining rings (7). Be sure one assembly (3) is turned 180 degrees in relation to the other.

g. Slide spring anchor assembly (10) on yoke and rod assembly (9). Slip punched hole of each torsion spring (5) over threaded stud on spring anchor assembly

and secure with hex nut (11).

h. Insert hinge clamp liner (19) into legs hinge clamp (20).

i. Insert counterbalance assembly (12) through

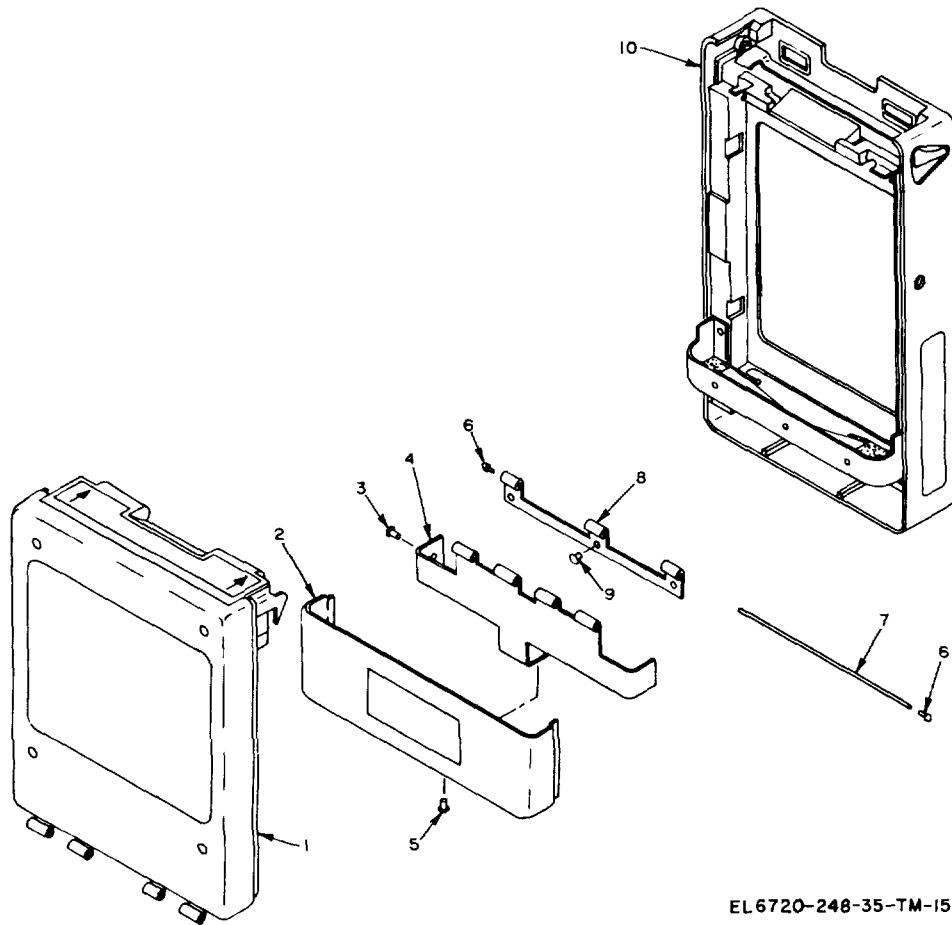

EL6720-248-35-TM-15

- | | | | |
|---|--------------------------|----|----------------------|
| 1 | Door assembly (A10) | 6 | Hinge plug (MP13) |
| 2 | Rear cover (MP17) | 7 | Hinge pin (MP11) |
| 3 | Rivet (MP28) | 8 | Door hinge (MP99) |
| 4 | Rear cover spider (MP23) | 9 | Rivet (MP96) |
| 5 | Rivet (MP33) | 10 | Divider frame (MP80) |

Figure 3-3. Camera back assembly, exploded view.

legs hinge (20) and guide bottom locator pin into center hole of hinge plug (25).

j. Locate end of outer tube (18) which has the three bored holes and insert this end first through legs clamp (20) and over the hinge plug (25). Rotate the tube to align tube holes with tapped holes in hinge plug, and then secure with three screws (24).

k. Install telescope clamp (14) on inner tube (2) at the tube end which has the ridge. Force

clamp over ridge by spreading split ring of clamp. Secure with screw (16). Insert telescope clamp liner (13) into telescope clamp.

l. There are two knob assemblies. Place washer (15) over the shorter knob assembly (17) and attach knob assembly to telescope clamp (14). Place washer (21) over the remaining knob assembly (22) and attach knob assembly to legs clamp (20).

m. Place tube plug (1) in end of inner tube

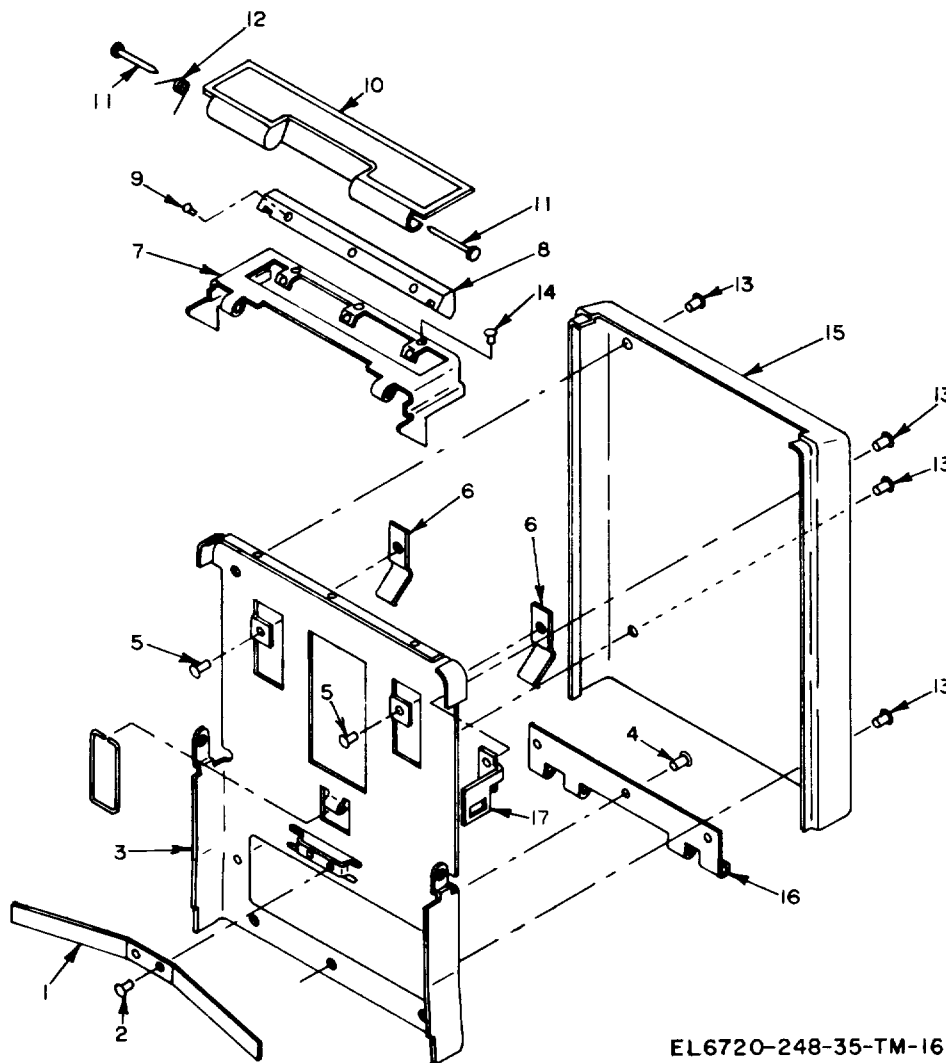

EL6720-248-35-TM-16

- | | | | |
|---|---------------------------|----|--------------------------------|
| 1 | Door spring (MP151) | 10 | Exit door assembly (A14) |
| 2 | Rivet (MP157) | 11 | Exit door pivot stud (MP141) |
| 3 | Rear door spider (MP90) | 12 | Exit door pivot spring (MP137) |
| 4 | Rivet (MP120) | 13 | Rivet (MP121) |
| 5 | Rivet (MP162) | 14 | Rivet (MP77) |
| 6 | Roll frame spring (MP159) | 15 | Rear door (MP69) |
| 7 | Exit cover spring (MP129) | 16 | Door hinge (MP99) |
| 8 | Exit guide bar (MP 132) | 17 | Roll latch (MP73) |
| 9 | Rivet (MP135) | | |

Figure 3-4. Door assembly A10, exploded view.

(2). Push down on inner tube and test counter balance action. Secure inner tube with knob assembly (17). Test tripod leg action and secure legs in normal position with knob assembly (22).

3-15. Disassembly of Support Arm Assembly
(fig. 3-7)

Disassemble the support arm assembly as follows:

a. Remove the support arm assembly from the camera assembly (para 3-7).

b. At each end of the support arm (1), remove two screws (6) and insulating washers (5). This action disassembles assembly (2), consisting of insulating pad (3); clip assembly (4), and also frees mask assembly (7).

c. Pull straight out on captive thumbscrews (8) while threading them out of support arm (1).

d. Loosen two screws (12) and lift junction box (9) from support arm (1).

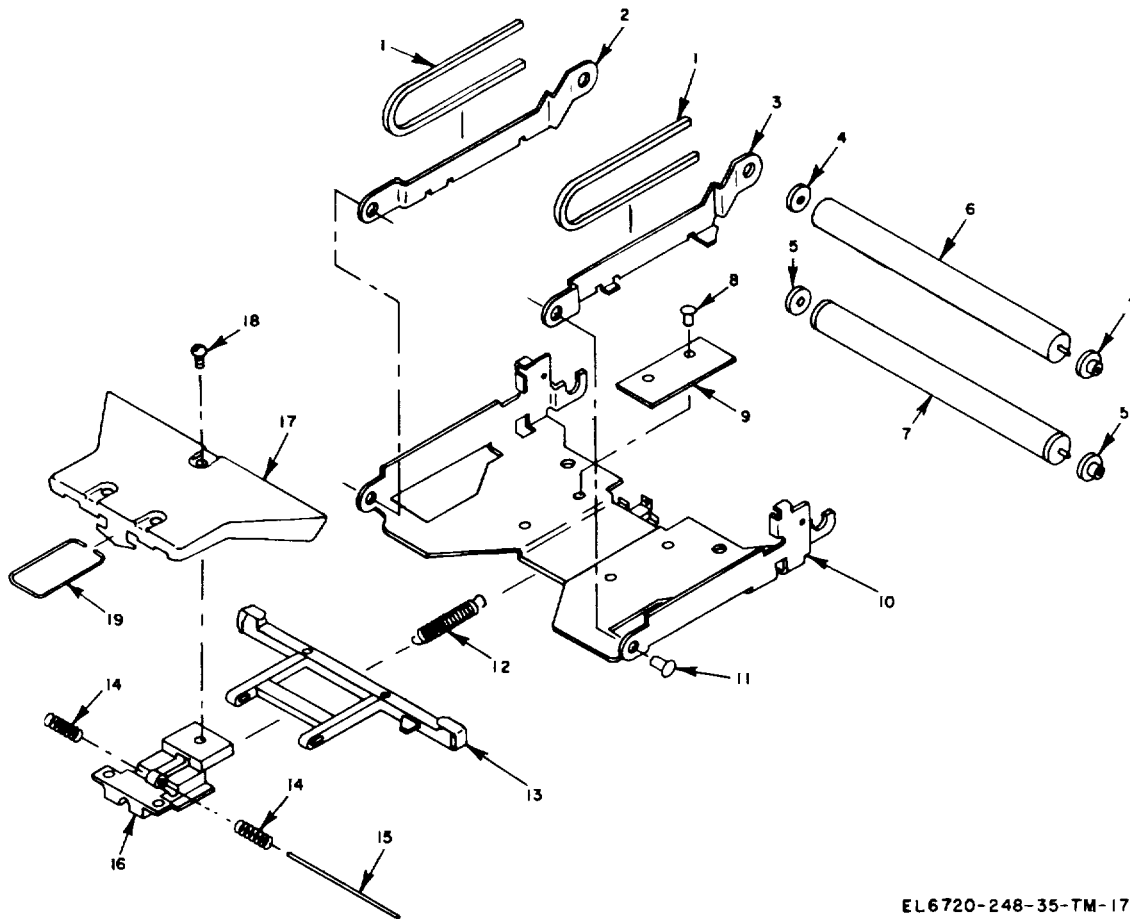

EL 6720-248-35-TM-17

- | | | | |
|----|-----------------------------------|----|---------------------------------|
| 1 | Spread roll spring (MP224) | 11 | Spread roll pivot (MP226) |
| 2 | Left front roll support (MP225) | 12 | Slide block spring (MP222) |
| 3 | Right front roll support (MIP203) | 13 | Edge control bar assembly (A12) |
| 4 | Roller bushing (MP215) | 14 | Locating spring (MP221) |
| 5 | Roller bushing (MP214) | 15 | Camera body shaft (MP220) |
| 6 | Front roller (MP217) | 16 | Slide block (MP227) |
| 7 | Rear roller (MP216) | 17 | Slide block cover (MP218) |
| 8 | Rivet (MP196) | 18 | Screw (MP219) |
| 9 | Slide plate (MIP194) | 19 | Slide block link (MP223) |
| 10 | Roller frame support (MP183) | | |

Figure 3-5. Frame roller support assembly A39, exploded view.

e. Unsolder leads of the two flash cords (15) and shutter cord (16) from circuit card assembly (10).

f. Remove three screws (13) from support arm (1), which frees circuit card assembly (10) and three spacers (11).

g. Pull the two flash cords (15) and shutter cord (16) out through grommet (14) and remove grommet from support arm (1).

3-16. Reassembly of Support Arm Assembly
(fig. 3-7)

Reassemble the support arm assembly as follows:

a. Attach insulating pad (3) and clip assembly (4) to support arm (1) with washers (5) and screws (6). Secure mask assembly (7) under screwhead at one support arm end.

b. Thread two captive thumbscrews (8) into support arm (1).

c. Press grommet (14) into support arm (1) and push the two flash cords (15) and the shutter cord (16) through the grommet. Adjust protruding lengths and lead dress per original configuration.

d. Attach circuit card assembly (10) to support arm (1) with three spacers (11) and three screws (13).

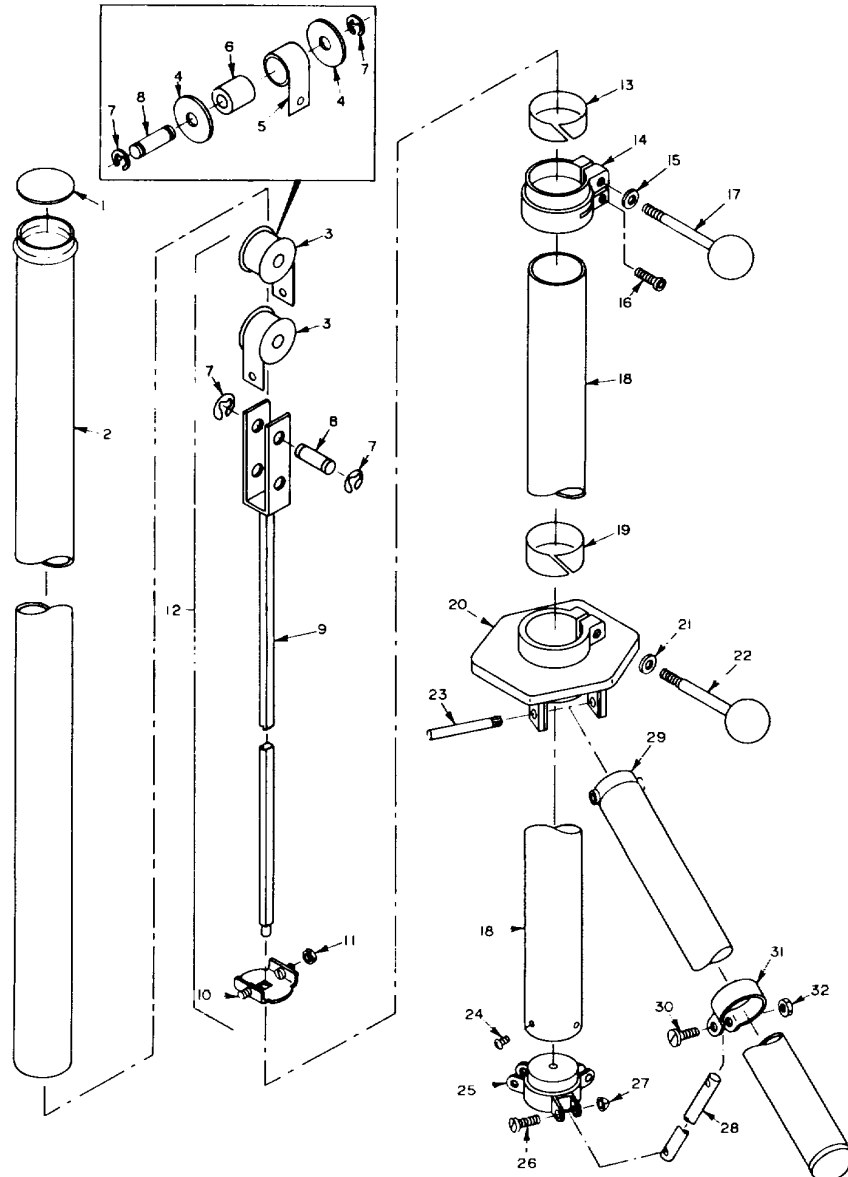

EL 6720-248-35-TM-18

- | | | | |
|----|-----------------------------------|----|-------------------------------------|
| 1 | Tube plug (MP114) | 17 | Telescope clamp knob assembly (A23) |
| 2 | Inner tube (MP117) | 18 | Outer tube (MP118) |
| 3 | Torsion spring and spool assembly | 19 | Hinge clamp liner (MP107) |
| 4 | Fiber washer (MP127) | 20 | Legs hinge (MP105) |
| 5 | Torsion spring (MP126) | 21 | Washer (MP119) |
| 6 | Counterbalance spool (MP125) | 22 | Hinge clamp knob assembly (A22) |
| 7 | Retaining ring (MP124) | 23 | Hinge stud (MP115) |
| 8 | Pin (IP123) | 24 | Screw (MP113) |
| 9 | Yoke and rod assembly (MP128) | 25 | Hinge plug (MP112) |
| 10 | Spring anchor assembly (A21) | 26 | Screw (MP109) |
| 11 | Hex nut (MP122) | 27 | Acorn nut (MP110) |
| 12 | Counterbalance assembly (A20) | 28 | Leg link (MP108) |
| 13 | Telescope clamp liner (MP106) | 29 | Leg assembly (A24) |
| 14 | Telescope clamp (MP103) | 30 | Screw (MP101) |
| 15 | Washer (MP11) | 31 | Leg clamp (MP100) |
| 16 | Screw (MP104) | 32 | Acorn nut (MP102) |

Figure 3-6. Tripod assembly, exploded view.

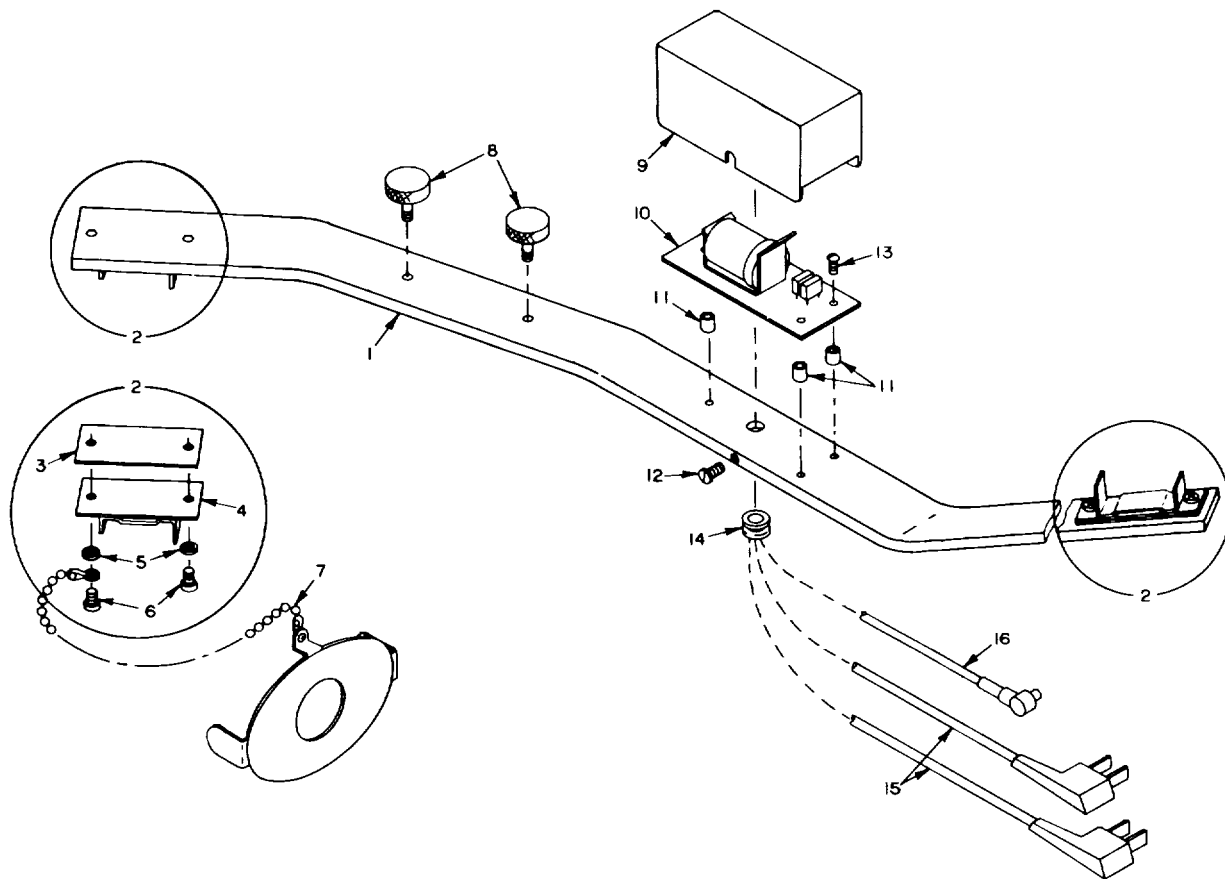

EL6720-248-35-TM-19

- | | | | |
|---|----------------------------|----|-----------------------------|
| 1 | Support arm (MP138) | 9 | Junction box (MP 139) |
| 2 | Assembly | 10 | Circuit card assembly (A27) |
| 3 | Insulating pad | 11 | Spacer (MP147) |
| 4 | Clip assembly (A26) | 12 | Screw (MP140) |
| 5 | Insulating washer | 13 | Screw (MP146) |
| 6 | Screw (MP142) | 14 | Grommet (MP143) |
| 7 | Mask assembly (A28) | 15 | Flash cord (W101, W102) |
| 8 | Captive thumbscrew (MP144) | 16 | Shutter cord (W103) |

Figure 3-7. Support arm assembly, exploded view.

e. Connect the two flash cords (15) and the shutter cord (16) to their terminals on the circuit card assembly (1).

f. Check for correct circuit lead dress and then attach junction box (9) to support arm (1) with two screws (12).

3-17. Disassembly of External Battery Charger (fig. 3-8)

The following disassembly procedure covers complete disassembly of the external battery charger. It should not be necessary to disassemble to this extent unless a complete rebuild is required. For normal troubleshooting, testing, and repair work, disassemble

only to the extent necessary. Disassemble the external battery charger as follows:

a. Remove the 14 screws (1) and end plate (2). Remove four rivets (3) and the two brackets (4) from end plate (2).

b. Remove nut (7), screw (5) and washer (6); this releases crimp terminal (8) from base (9).

c. Slide the plate and timer assembly (A49) and terminal board assembly (ASO0) out of base (9). Remove the four rubber bumpers (10) from base (9). Remove long pad (11) and two short pads (12).

d. Loosen the two screws at the rear of the

timer (13) and free the two solderless terminals (14); this frees the plate and timer assembly (A49).

(1) Loosen the two setscrews in control timer knob (15) and lift off knob.

(2) Remove two screws (16), two spacers (17) and panel (18) from timer (13).

e. Unsolder the wiring from the ac power cord (19); remove strain relief (20) freeing the ac power cord (19) from end plate (21). Remove four rivets (22) and the two brackets (23) from end plate (21).

f. Disassembly of terminal board assembly (A50) (fig. 3-9).

(1) Remove four screws (1), four nuts (2), four washers (3), and four spacers (4) from the terminal board (5).

(2) Unsolder the 10 leads from the transformer (6). Remove two screws (7), two nuts (8), two washers (9), two spacers (10), and two plates (11); freeing transformer (6) from terminal board (5).

(3) Unsolder the two leads from the pilot lamp (12); remove two brass eyelets (13) and pilot lamp assembly (A51) and lamp bracket (14) from terminal board (5).

(4) Remove electrical tape and insulating tubing (15) from pilot lamp.

(5) Carefully unsolder and remove the four resistors (16) and the four diodes (17) from the terminal board (5).

(6) Remove the two solderless terminals (18) from the terminal board (5).

(7) Remove eight rivets (19), eight interlock terminals (20), and the eleven solder terminals (21) from terminal board (5).

3-18. Reassembly of External Battery Charger

(fig. 3-8)

Reassemble the external battery charger as follows:

a. Reassembly of terminal board assembly (A50) (fig. 3-9).

(1) Secure the eight interlock terminals (20) to the rivets (19).

(2) Secure the eleven solder terminals (21) to terminal board (5).

(3) Place insulating tubing (15) over pilot

lamp (12) diode lead and wrap electrical tape around tubing (15) and other pilot lamp (12) lead.

(4) Secure pilot lamp assembly (A51) and lamp bracket (14) to terminal board (5) with two brass eyelets (13).

(5) Secure four spacers (4) to terminal board (5) with four screws (1), four washers (3) and four nuts (2).

(6) Secure transformer (6), two plates (11), and two spacers (10) to terminal board (5) with two screws (7), two washers (9), and two nuts (8). See figure 3-8 for (7) and (8) below:

(7) Secure two brackets (23) to the end plate (21) with four rivets (22).

(8) Secure ac power cord (19) to end plate (21) with the strain relief (20); insure ac power cord (19) leads will reach appropriate terminals before pressing strain relief (20) in place.

(9) Utilize figure 2-12 also and solder transformer (6) wiring, pilot lamp (12) wiring, the two solderless terminal (18) leads, the two ac power cord leads, the four resistors (16), and the four diodes (17) to the terminal board (5).

b. Secure timer (13) and two spacers (17) to panel (18) with two screws (16).

c. Place control timer knob (15) on timer (13) and secure by tightening the two setscrews.

d. Position timer assembly (A49) on terminal board assembly (A50); place the two solderless terminals (14) under the two screws at the rear of the timer (13) and secure by tightening the two timer screws.

e. Press the four rubber bumpers (10) into place on the base (9).

f. Slide the plate and timer assembly (A49) and the terminal board assembly (A50) into the base (9).

g. Secure crimp terminal (8) to base (9) with screw (5), washer (6), and nut (7).

h. Place long pad (11) and the two short pads (12) on the terminal board assembly (A50).

i. Secure the two brackets (4) to the end plate (2) with four rivets (3).

j. Position end plates (2) and (21) to the base (9) and secure with 14 screws (1).

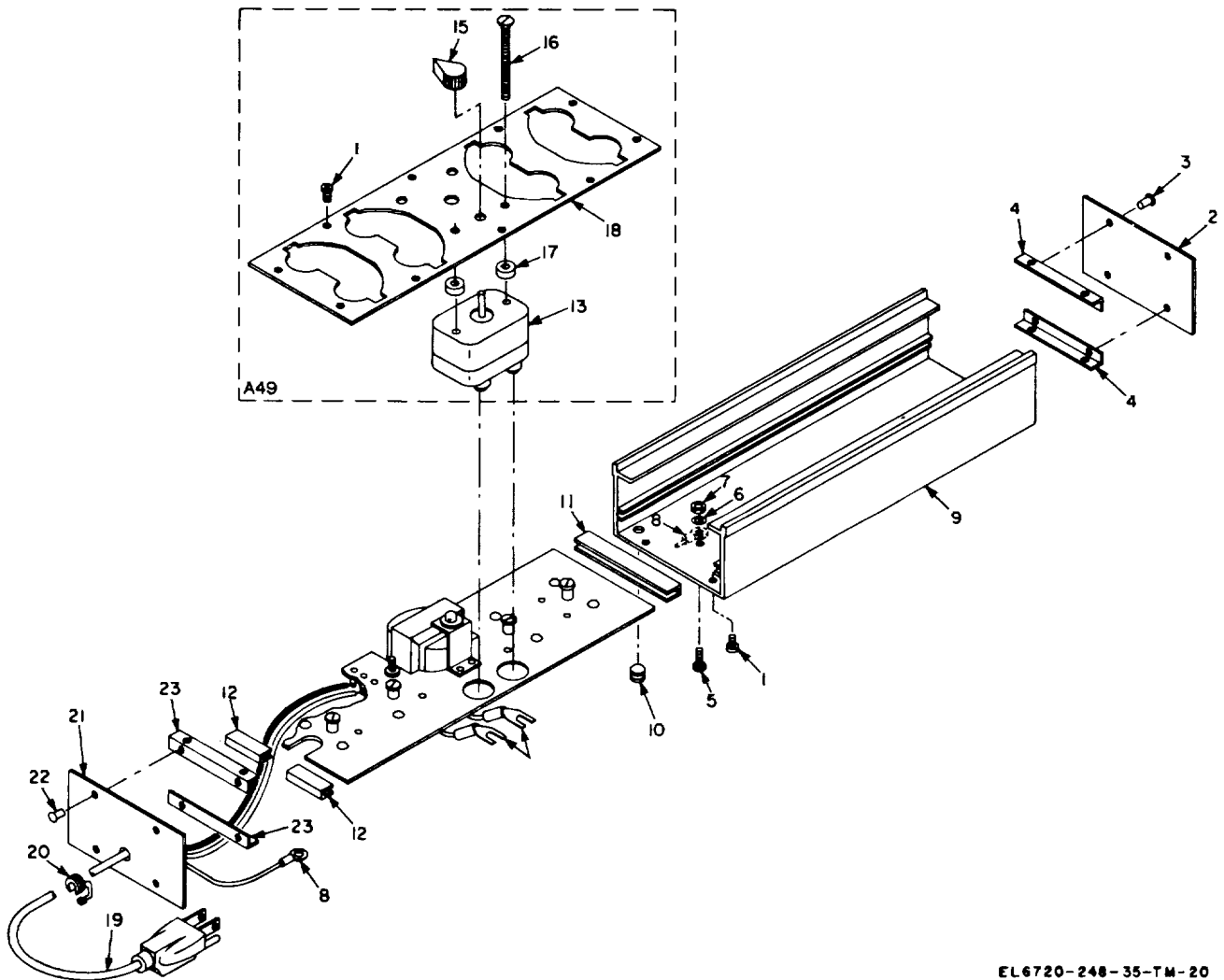

EL6720-248-35-TM-20

- | | | | |
|----|------------------------|----|------------------------------|
| 1 | Screw (MP262) | 13 | Timer (M401) |
| 2 | End Plate (M269) | 14 | Solderless terminals (MP294) |
| 3 | Rivet (MP268) | 15 | Control timer knob (MP274) |
| 4 | Bracket (MP267) | 16 | Screw (MP278) |
| 5 | Screw (MP264) | 17 | Spacer (MP279) |
| 6 | Washer (MP265) | 18 | Panel (MP280) |
| 7 | Nut (MP266) | 19 | Ac power cord (W401) |
| 8 | Crimp terminal (MP263) | 20 | Strain relief (MP281) |
| 9 | Base (MP261) | 21 | End plate (MP272) |
| 10 | Rubber bumper (MP273) | 22 | Rivet (MP271) |
| 11 | Long pad (MP276) | 23 | Bracket (MP270) |
| 12 | Short pad (MP277) | | |

Figure 3-8. External battery charger, exploded view.

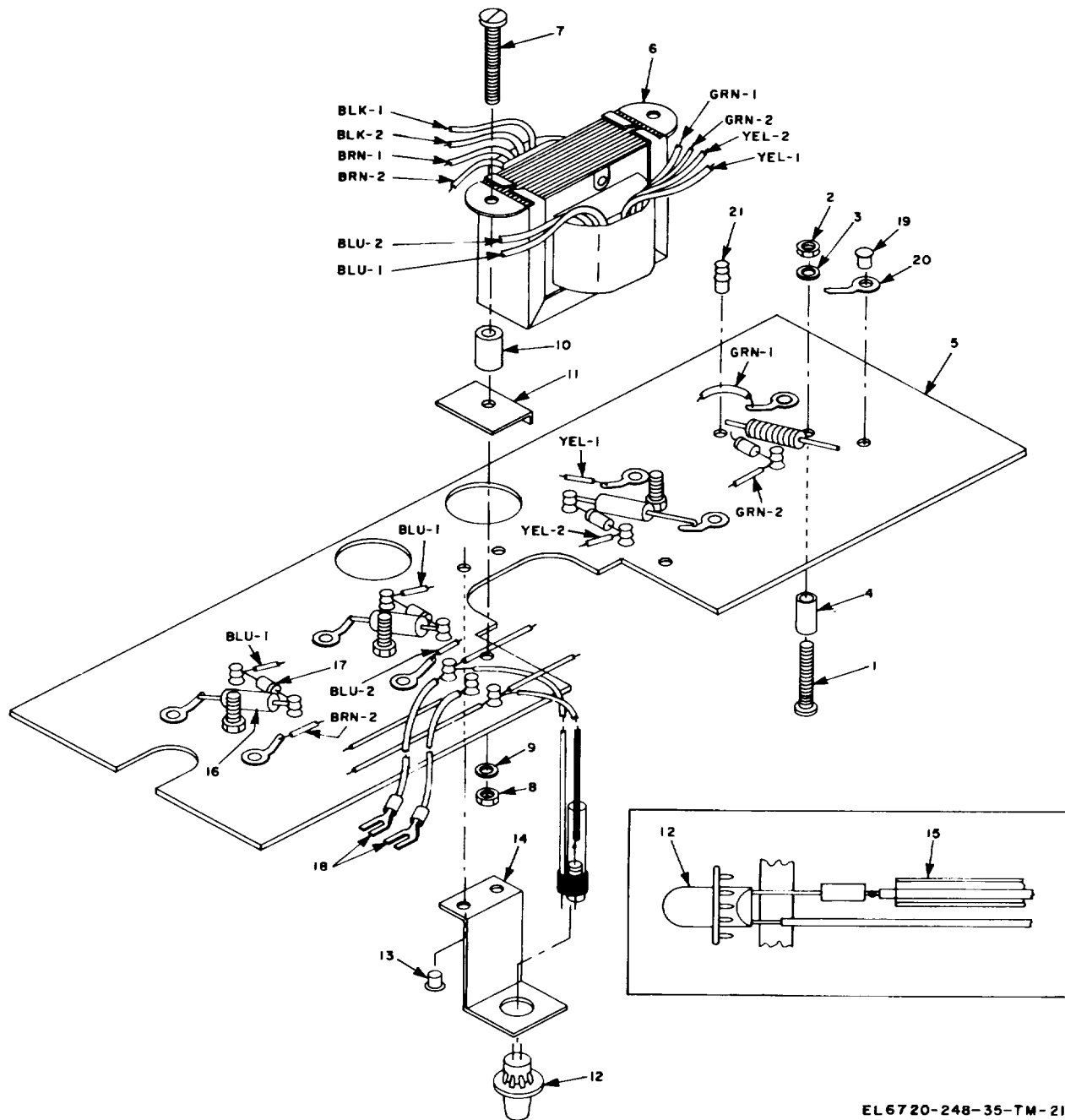

EL 6720-248-35-TM-21

- | | | | |
|----|------------------------|----|--|
| 1 | Screw (MP286) | 12 | Pilot lamp (DS401) |
| 2 | Nut (MP289) | 13 | Brass Eyelet (MP283) |
| 3 | Washer (MP288) | 14 | Lamp bracket (MP282) |
| 4 | Spacer (MP287) | 15 | Insulating tubing (MP284) |
| 5 | Terminal board (MP290) | 16 | Resistor (R401, R402, R403, and R404) |
| 6 | Transformer (T401) | 17 | Diode (CR401, CR402, CR403, and CR404) |
| 7 | Screw (MP295) | 18 | Solderless terminal (MP294) |
| 8 | Nut (MP298) | 19 | Rivet (MP292) |
| 9 | Washer (MP297) | 20 | Interlock terminal (MP291) |
| 10 | Spacer (MP296) | 21 | Solder terminal (MP293) |
| 11 | Plate (MP285) | | |

Figure 3-9. Terminal board assembly (A50), exploded view.

**CHAPTER 4
DIRECT SUPPORT TESTING PROCEDURES**

4-1. Scope of Direct Support Testing Procedures

a. The testing procedures consist of physical tests and inspections (para 4-2), and an overall test of the camera set (para 4-3). Test procedures for the lens and shutter assembly are given in paragraph 5-5.

b. Read the instructions in each paragraph before proceeding to the applicable chart. Perform the test steps in sequence and do not skip steps. Operation of each step within the limits of the performance standard given by the chart is required before the camera set can be returned to the using organization or

to stock.

4-2. Physical Tests and Inspection

a. Test Equipment and Materials.

(1) Polaroid-land film, black and white, type 107.

(2) No. 1 photofloodlamp and reflector.

b. Test Connections or Conditions. Prepare the camera set for operation (TM 11-6720-248-12), but do not load film at this time.

c. Procedure.

Step No.	Control settings		Test procedure	Performance standard
	Test equipment	Equipment under test		
1	None-----	None-----	<p>a. Inspect camera set for loose or missing nuts, screws and rivets.</p> <p>b. Inspect all cables and connectors.</p> <p>c. Inventory all accessories; including titleboard character sets.</p> <p>d. Inspect all surfaces for scratches, dents, and damaged finish.</p> <p>Note. Touchup painting is recommended in lieu of refinishing whenever practicable. Do not paint plated surfaces or connectors, or polish them with abrasives.</p>	<p>a. All nut, screws, and rivets secure; none missing.</p> <p>b. All secure; none loose, missing or damaged.</p> <p>c. Nothing missing or damaged. The characters are sorted in the plastic cases.</p> <p>d. No scratches exposing bare metal, or damage to paint finish. No cracked or warped Plastic materials. Rubber bumpers and grommets in place and not damaged.</p>
2	None-----	None-----	<p>a. Disassemble titleboard and horizontal positioning bar and remove and reattach to camera assembly.</p> <p>b. Remove and reattach strobe assembly.</p> <p>c. Remove and reattach support arm assembly.</p> <p>d. Remove and reattach camera assembly to tripod.</p> <p>e. Open and close tripod and operate telescoping inner tube with camera assembly removed.</p>	<p>a. Titleboard clamps securely and disassembles freely without binding. Horizontal positioning bar attaches and detaches smoothly from camera assembly.</p> <p>b. Quick-release clamps operate smoothly and hold firmly</p> <p>c. Thumbscrews secure assembly properly and do not bind.</p> <p>d. Setscrew works properly; camera assembly does not bind on tripod.</p> <p>e. There is no binding of legs or leg links or clamps. Counter-balance works smoothly; tripod stands firm.</p>

Step No.	Control settings		Test procedure	Performance standard
	Test equipment	Equipment under test		
3	None -----	None-----	<p>a. Check back assembly doors, hinges, latches, and all interior assembly.</p> <p>b. Check al' external surfaces for dents, damage to paint finish, or to labels and printed instructions.</p>	<p>a. Doors operate smoothly without warp or hinge bind. Door latches secure doors correctly. No bent or misaligned surfaces and no burrs. No damage to paint finish.</p> <p>b. No damage to fabric covering. Labels and instructions intact and legible.</p>
4	None -----	<p>Iris diaphragm control lever: 4.5; shutter speed control: 30. Disconnect shutter cord from jack on lens and shutter assembly.</p> <p>Change shutter speed to 60 and rotate back assembly.</p> <p>Change shutter speed to 125 and rotate back assembly.</p> <p>Change shutter speed to T and rotate back assembly.</p> <p>Change shutter speed to B and rotate back assembly.</p>	<p>a. Open back assembly and view lens from rear while tripping shutter.</p> <p>b. Attempt to trip shutter again.</p> <p>c. Rotate beck assembly 180 degrees clockwise; then attempt to trip shutter.</p> <p>a. View lent from rear while tripping shutter.</p> <p>b. Same as a above-----</p> <p>a. View lent from rear while tripping shutter.</p> <p>b. View legs from rear while tripping shutter.</p> <p>View lens from rear while tripping shutter.</p>	<p>a. Shutter trips; actuate button operates without binding.</p> <p>b. Shutter will not trip; double exposure prevention device operational.</p> <p>c. Rotation is smooth and detent positive. Shutter trips and double exposure prevention device releases properly; shutter cocks.</p> <p>a. Shutter trips and back assembly must be rotated to recock shutter.</p> <p>b. Same as a above.</p> <p>a. Shutter opens and remains open. Shutter will not trip again until back assembly is rotated. Rotating the back assembly does not close the shutter.</p> <p>b. Shutter closes.</p> <p>Shutter opens and remains open. Shutter closes when back assembly is rotated.</p>
5	None -----	None-----	Inspect stereoscope; remove and reattach to camera assembly.	Assembly is undamaged. Mirrors clean and undamaged. Thumbscrew works normally and assembly attaches without binding.
6	None -----	None-----	Inspect density filter (cap and lens assembly). Remove and reattach to camera assembly.	Assembly clean and undamaged. Attaches firmly to lens and shutter assembly without binding or play.
7	None -----	Operation of diaphragm and shutter speed adjustments.	Inspect lens and shutter assembly. Check speed control and diaphragm adjustments.	No scratches on lens surfaces. Diaphragm adjusts smoothly but without play. Speed control operates smoothly with positive detent action.
8	None -----	Shutter speed control: 125. Connect shutter cord to jack on lens and shutter assembly. Set strobe assemblies function switch to position A (model 600) or to OFF position (model 700) and connect ac power cord.	<p>a. Depress actuate button ac mode.</p> <p>b. Rotate back assembly. Change strobe assembly function switch to B (model 600) or to ON position(model 700). Depress actuate button.</p>	<p>a. Strobe assemblies flash in the</p> <p>b. Strobe assemblies flash in the battery mode.</p>

Step No.	Control settings		Test procedure	Performance standard
	Test equipment	Equipment under test		
9	None -----	Same as step 8-----	a. Same as step 8a----- b. Same as step 8b-----	a. Strobe assemblies ready to flash within 25 seconds after function switch is set to position A (model 600) or to OFF position (model700). b. Strobe assemblies ready to flash within 15 seconds after function switch is set to position B (model 600) or to ON position (model700). Neon indicator comes on within 15 seconds after flash.
10	Photoflood-lamp.	Load with black and white film.	Expose all external areas of the camera assembly to the light from a No. 1 photofloodlamp at approximately 1 foot distance. Develop print.	Print is completely black, no indication of light leakage.

4-3. Operational Tests and Inspection

a. Test Equipment and Materials.

(1) A 115-volt ac, 60-Hz power source is required to test ac operation of the strobe assemblies and to test the operation of the external battery charger.

(2) Polaroid-Land film: one black and white film pack type 107 and one color film pack type 108 required for live tests of the camera set.

(3) Type 53 lamp with socket and probe

leads.

b. Test Connections and Conditions.

(1) Prepare the camera set for operation and load with black and white film (TM 11-6720-248-12).

(2) Select a neutral, evenly lighted background which is uncluttered and free of high contrast. The subject should not wear highly contrasting garments or especially dark garments.

c. Procedure.

Step No.	Control settings		Test procedure	Performance standard
	Test equipment	Equipment under test		
1	None -----	Density filters in place on lens and on strobe assembly. Black and white film load. Strobe assemblies: function switch in position A (model 600) or OFF position (model700) and ac power cord connected. Camera assembly: iris diaphragm at 5.6 and shutter speed control at 125.	Position subject at titleboard and make exposure. Pull white and yellow film tabs and develop. Note. Characters may be placed on the titleboard to assist in checking focus.	Print has good focus and contrast. No fog or light streaks. No light leaks into unused half of frame. Note. Take into account the influence of ambient temperature on developing time.
2	None -----	As in step 1, but strobe assembly function switch to position B (model 600) or ON position (model 700).	Same as step 1, but rotate back assembly and make exposure on both halves of frame.	Print quality as described in step 1.
3	None -----	Remove density filters from lens and from strobe assembly. Disconnect shutter cord at jack on lens and	Make an exposure with available light for an isolated test of the shutter; to test timing accuracy.	Print quality as described in step 1.

Step No.	Control settings		Test procedure	Performance standard
	Test equipment	Equipment under test		
4	None -----	shutter assembly. Adjust exposure with light meter(ASA 3000), but do not use T or B diaphragm settings. Same as step 1, but with density filters removed from lens and from strobe assembly. Remove the black and white film pack and use the color film pack.	Position subject at titleboard and make exposure. Rotate back assembly, and change strobe assemblies function switch to position B (model600) or OFF position (model700). Make P second exposure.	Print has good focus and contrast and good color fidelity. No appreciable difference between first and second exposure. No fog, light leaks, or scratches on emulsion.
5		Battery charger control set for one hour.	Time the timer and place lamp probes across rivet contacts in each charging position.	Pilot lamp illuminates. Timer times out in one hour - 10%. Test lamp lights in each of the four charging positions.

CHAPTER 5 GENERAL SUPPORT MAINTENANCE

5-1. Scope of General Support Maintenance Procedures

General support maintenance procedures include the maintenance procedures authorized to lower levels of maintenance (operator, organizational, and direct support), as well as those covered in this Chapter. The procedures described herein consist of disassembly (para 5-3), reassembly (para 5-4), and testing (para 5-5). Do not disassemble beyond what is necessary to effect repair.

5-2. Tools, Materials, and Test Equipment Required for General Support Maintenance

The following tools, materials, and test equipment are required; in addition to those listed in paragraph 3-2.

- a. Tools. Toolkit, Photographic Repair TK-109/GF.
- b. Test Equipment and Materials. None required.

5-3. Disassembly of Lens and Shutter Assembly (fig. 5-1)

Remove the lens and shutter assembly from the camera assembly (para 3-10c and 3-10f). Disassemble the lens and shutter assembly as follows:

- a. Remove front lens element (39) and rear lens element (1) from housing (44).
- b. Remove four screws (4) and remove iris diaphragm assembly (5, 7, 8, 9), attached to iris diaphragm housing (3).
- c. Remove two screws (6) and detach iris diaphragm assembly (5, 7, 8, 9) from iris diaphragm housing (3).
- d. Remove the five leaves of the shutter (10) from the shutter retaining plate (11).
- e. Remove shutter retaining plate (11) from housing (44).

- f. Remove screw (26) and shutter actuator lever (25).

- g. Remove speed cam lever (12). Lift the right side away from housing (44) and withdraw to the right, to release it from speed cam spring (28).

- h. Remove locking lever (13) from pivot release plate (18).

- i. Remove retaining ring (17). Detach arm of spring (14) from release lever (16), and remove release lever.

- j. Remove two screws (19) and pivot release plate (18). Release lever spring (14) and locking lever spring (15) remain attached to pivot release plate (18).

- k. Remove speed cam release lever (27) and speed cam spring (28).

- l. Remove retaining ring (30). Remove cocking lever spring (31). Remove cocking lever (29). Spring (32) and spring (33) remain attached to cocking lever (29).

- m. Remove four screws (41), identification plate (40), shutter speed adjusting ring (42), and detent (43).

- n. Disconnect shutter return spring (22) from screw (35). Remove shutter release lever (21), and shutter release spring (20).

- o. Remove screw (36), screw (35), and timer mechanism assembly (34).

- p. Remove two screws (38) and indicator plate (37).

5-4. Reassembly of Lens and Shutter Assembly (fig. 5-1)

- a. Attach the indicator plate (37) with two screws (38).

- b. Install timer mechanism assembly (34) with screw (35) and screw (36).

c. Attach shutter return spring (22) to shutter release lever (21). Attach shutter release spring (20) to housing (44). Install release lever in housing; bearing on shutter release spring. Attach shutter return spring (22) to screw (35).

d. Install shutter speed adjusting ring -(42) and detent (43). Secure identification plate (40) to housing (44) with four screws (41).

e. Position spring (32) and spring (33) on cocking lever (29). Install cocking lever. Install cocking lever spring (31) on cocking lever. Attach retaining ring (30).

f. Install speed cam spring (28) and speed cam release lever (27).

g. Position release lever spring (14) and locking lever spring (15) on pivot release plate (18). Attach pivot release plate with two screws (19).

h. Start release lever (16) under the release lever spring (14) and slide into position. Be sure release lever is fitted correctly over the tab on shutter release lever (21). Complete the attachment of release lever spring (14) and be certain it is seated properly at its pivot point on pivot release plate (18). Attach retaining ring (17).

i. Install locking lever (13) and connect to arm of locking lever spring (15).

j. Attach iris diaphragm assembly (5, 7, 8, 9) to iris diaphragm housing (3) with two screws (6).

k. Insert arm of speed cam spring (28) into hole of tab on speed cam lever (12), and position speed cam lever in housing (44). Assembly is under tension.

Hold in position and install shutter actuator lever (25) with screw (26). Be sure shutter switch is not bent during this operation.

l. Attach iris diaphragm (3) to housing (44) with four screws (4).

m. Install front lens element (39) and rear lens element (1).

5-5. Testing of Lens and Shutter Assembly

a. Testing procedures are prepared for use by organizations responsible for general support maintenance of electronic equipment to determine the acceptability of repaired equipment. The procedures set forth specific requirements that the repaired lens and shutter assembly of the camera set must meet before it is returned to the using organization or to stock. The testing procedure may also be used as a guide by direct support personnel for testing equipment that has been repaired by them if the required tools and test equipment are available.

b. The testing procedure consists of physical tests and inspections (para 5-6), lens and shutter assembly operational tests (para 5-7), and lens and shutter focus test (para 5-8). An overall operational test of the camera set is provided in paragraph 4-3. Comply with the instructions preceding the body of the chart before proceeding to the chart. Perform each step in sequence; do not vary the sequence. For each step, perform all the actions required in the control settings column; then perform each specific test procedure and verify it against the performance standard.

1	Lens assembly (rear) (MP36)	23	Button release socket (MP59)
2	Plain round nut (MP29)	24	Screw (MP60)
3	Iris diaphragm housing (MP31)	25	Shutter actuator lever (MP38)
4	Screw (MP32)	26	Screw (MP39)
5	Retaining plate (MP52)	27	Speed cam release lever (MP45)
6	Screw (MP53)	28	Speed cam spring (MP68)
7	Spring washer (MP72)	29	Cocking lever (MP40)
8	Iris diaphragm leaf (MP34)	30	Retaining ring (MP58)
9	Adjusting ring (MP55)	31	Cocking lever spring (MP62)
10	Shutter leaf (MP35)	32	Cocking lever spring (MP63)
11	Shutter retaining plate (MP54)	33	Actuator lever spring (MP61)
12	Speed cam lever (MP44)	34	Timer mechanism assembly (A7)
13	Locking lever (MP41)	35	Screw (MP70)
14	Release lever spring (MP65)	36	Screw (MP71)
15	Locking lever spring (MP64)	37	Indicator plate (MP48)
16	Release lever (MP42)	38	Screw (MP49)
17	Retaining ring (MP57)	39	Lens assembly (front) (MP37)
18	Pivot release plate (MP50)	40	Identification plate (MP46)
19	Screw (MP51)	41	Screw (MP47)
20	Shutter release spring (MP67)	42	Shutter speed adjusting ring (MP56)
21	Shutter release lever (MP43)	43	Detent (MP30)
22	Shutter return spring (MP66)	44	Lens and shutter assembly housing (A6)

Figure 5-1. Lens and shutter assembly, exploded view.

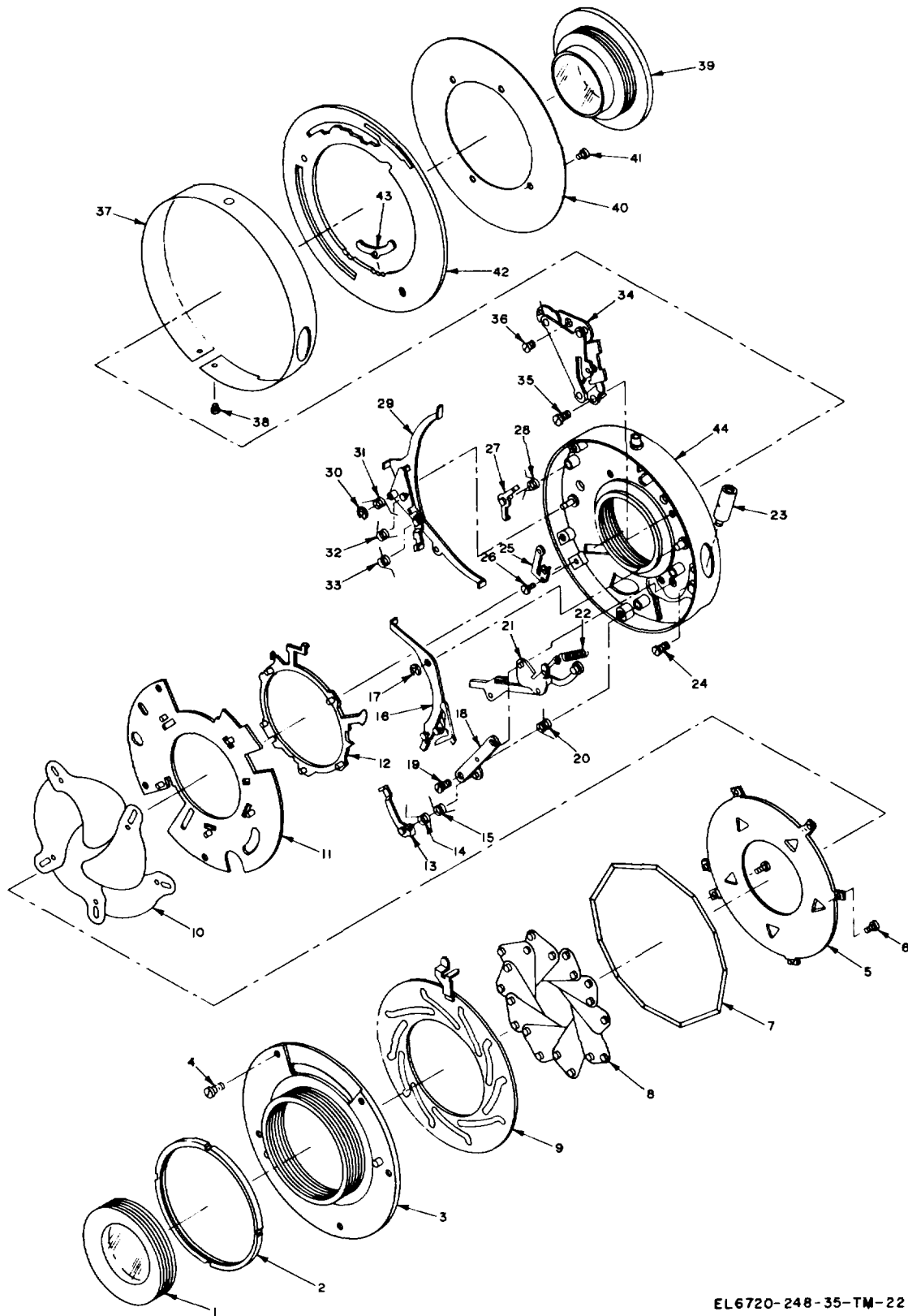

EL6720-248-35-TM-22

Figure 5-1.-Continued

5-6. Physical Tests and Inspections

a. Test Equipment and Materials. None required.

b. *Test Connections or Conditions.* Install lens and shutter assembly on the adjustable cell (3, fig. 3-2) in accordance with paragraph 3-11f.

c. *Procedure.* Refer to paragraph 4-2c, steps No. 1, 4, and 7 for physical tests and inspections pertaining to the lens and shutter assembly.

b. *Test Connections or Conditions.*

(1) Set up motion analyzer and the lens and shutter assembly as shown in figure 5-2. Insure the lens and shutter assembly is centered over the opening in the photocell housing. Place tolerance chart over motion analyzer screen.

(2) Verify motion analyzer has been properly calibrated and position switches as follows:

<i>Switch</i>	<i>Position</i>
POWER-----	ON
S R-----	S
FUNCTION-----	A
TIME IN SECONDS-----	.0468
Photocell lamp-----	Low

5-7. Lens and Shutter Assembly Operational Tests

a. *Test Equipment and Materials.* Analyzer, Motion LS-76.

c. *Procedure.*

Step No.	Control settings		Test procedure	Performance standard
	Test equipment	Equipment under test		
1	Motion Analyzer Refer to para 5-7b (2).	Shutter speed set at 30 and iris diaphragm at 4.5.	a. Trip shutter and watch waveform on motion analyzer screen with tolerance chart overlay. b. Set FUNCT-ON switch to C. Trip shutter and watch waveform on motion analyzer screen with tolerance chart overlay.	a. Shutter speed waveform is within the -10% areas shown on tolerance chart (fig. 5-3). b. Flash synchronization waveform starts at the same time the shutter starts to open (fig. 5-3).n
2	Same as step 1 except time in seconds is .0235.	Shutter speed set at 60 and iris diaphragm at 4.5.	a. Same as step 1a ----- b. Same as step 1a -----	a. Same as step 1a. b. Same as step 1b.
3	Same as step 1 except time in seconds is .0112.	Shutter speed set at 125 and iris diaphragm at 4.5.	a. Same as step 1a ----- b. Same as step 1b -----	a. Same as step 1a. b. Same as step 1b.

5-8. Lens and Shutter Focus Test

a. Test Equipment and Materials. Focusing screen (ground glass).

b. *Test Connections and Conditions.* Assemble the camera set in accordance with paragraph 3-11.

c. *Procedure.* Perform focus test in accordance with paragraph 3-12.

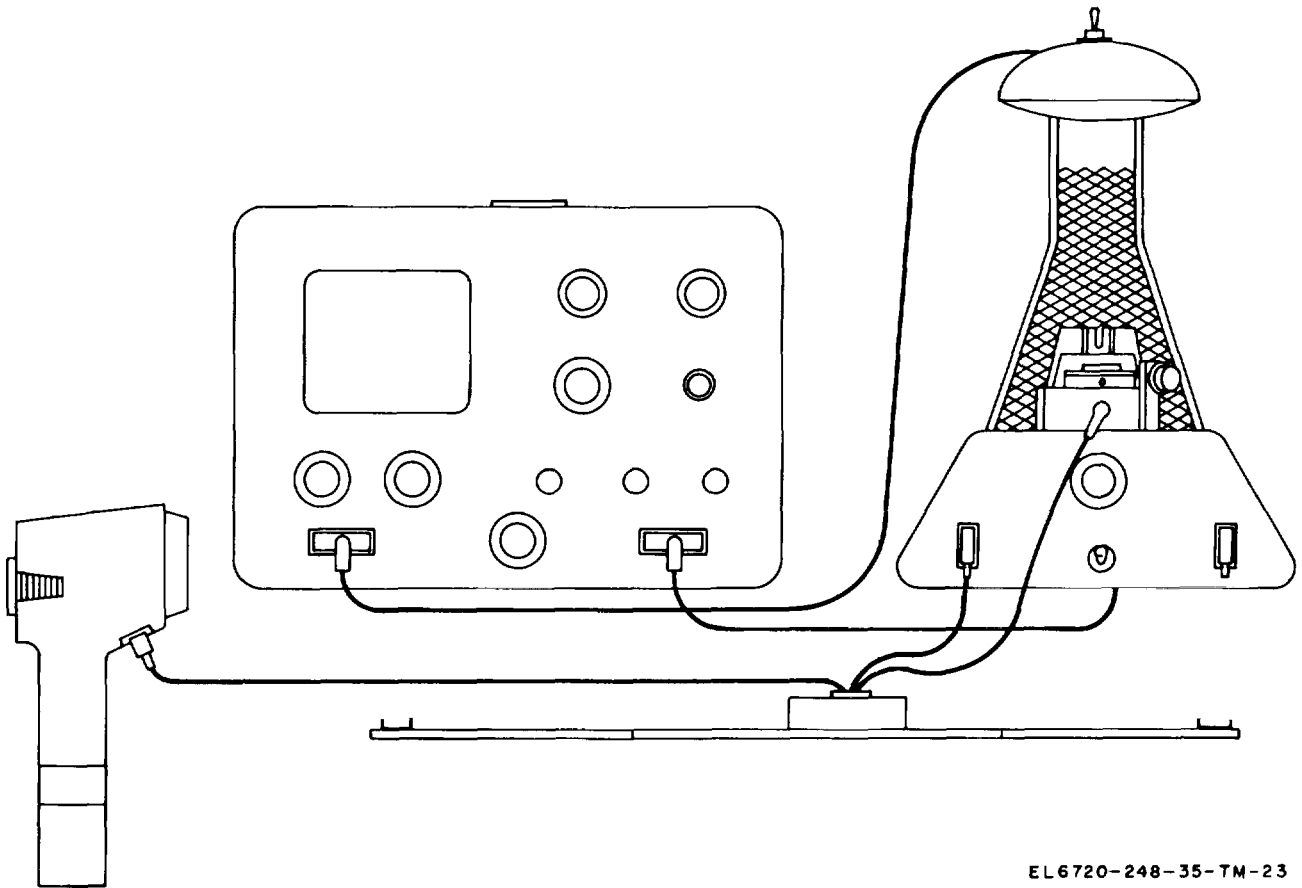

EL 6720-248-35-TM-23

Figure 5-2. Lens and shutter assembly test setup.

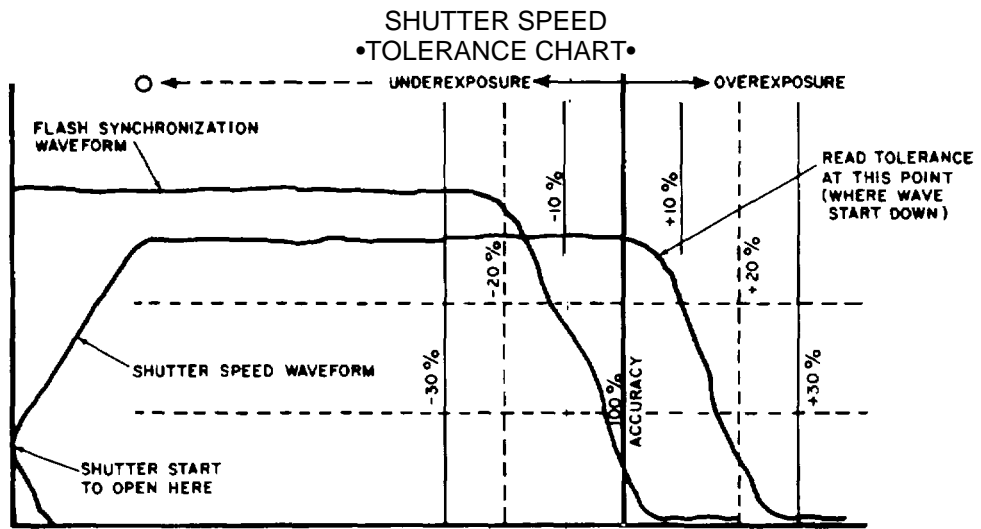

NOTE: FLASH SYNCHRONIZATION WAVEFORM MUST START AS SHUTTER OPENS;
IT IS IMMATERIAL WHERE WAVEFORM STARTS DOWN.

EL6720-248-35-TM-24

Figure 5-3. Shutter speed and flash synchronization waveforms.

CHAPTER 6 DEPOT MAINTENANCE

Section I. GENERAL

6-1. General

It is the primary purpose of this chapter to disclose maintenance procedures for the strobe assemblies; no part of which is duplicated in maintenance procedures at lower levels in this manual. Maintenance philosophy is based upon the fact that strobe assemblies will require either battery replacement (TM 11-6720-248-12) or maintenance at depot level. This is indicated by the method of assembly, the packing density of parts, and the complexity of the assembly. Paragraphs and illustrations pertaining to either the model 600 or model 700 strobe assemblies only, will be so titled.

6-2. Scope of Depot Maintenance of the Camera Set

Depot maintenance consists generally of overhauling unserviceable equipment. Overhaul is defined as the restoration of unserviceable equipment to completely serviceable condition; with performance equivalent to new equipment. The extent of such work will be defined by the facility performing the work; depending upon the component of the camera set at fault. Excepting the strobe assemblies, procedures are given in TM 11-6720-248-12 and portions of this manual. For the strobe

assemblies, if battery replacement does not effect repair, perform maintenance procedures as given in this chapter; or overhaul as deemed necessary.

6-3. Scope of Depot Maintenance of the Strobe Assemblies

It is recommended that maintenance begin with a thorough visual inspection; followed by basic continuity checks to insure that there are no conditions that will introduce further trouble when ac line voltage is applied. Disassembly to the extent given in paragraphs 6-9 (model 600) and 6-13 (model 700) is sufficient for performing maintenance routines. Further disassembly information is given in paragraphs 6-10 (model 600) and 6-14 (model 700) if this should be necessary to perform overhaul. Disassembly beyond this constitutes removal and replacement of electronic components or a complete rebuild; then appropriate wiring diagram or parts location illustration should be consulted. Initial inspection will sometimes disclose a fault so that isolation may be made without the need for the troubleshooting chart. Inen, the testing procedures of paragraphs 6-19 (model 600) and 6-20 (model 700) may be performed immediately. Refer to figure 6-13 for resistor-capacitor information.

Section II. TROUBLESHOOTING

WARNING

Be extremely careful when troubleshooting a strobe assembly. Potentials in excess of 500 volts are present. Be especially careful when handling the cap and housing assembly. Capacitors in the handle retain a lethal charge. Use insulated test probes when measuring voltages. Before disassembling the strobe assembly, comply with the instructions in the warning notice at the beginning of this manual.

6-4. General

The troubleshooting routines at the organizational maintenance level (TM 11-6720-248-12) and those contained in chapter 3 provide sectionalization to the strobe assembly. This section contains the routines for localization and isolation.

6-5. Tools, Materials, and Test Equipment Required for Strobe Assembly Troubleshooting

The following tools, materials, and test equipment are required to troubleshoot the strobe assemblies:

- a. Tools. No special tools are required.
- b. Materials. None required.
- c. Test Equipment.
 - (1) Oscilloscope AN/USM-281.
 - (2) Multimeter TS-352/U.
 - (3) AC ammeter.
 - (4) DC power supply.
 - (5) One 1K ohm 1/2w resistor.
 - (6) Four Ni-Cad "D" cells (fully charged).
 - (7) DC ammeter.
 - (8) Light meter.
 - (9) Isolation transformer.

probable troubles, and checks and corrective measures.

CAUTION

If unit is operated in ac or charge, connect an isolation transformer between the ac line and the ac input before any test equipment is connected to the units, see figure 6-3.

b. Not all waveforms (fig. 6-2) are mentioned in the troubleshooting chart. The extra ones (some of faulty conditions) are provided as an aid if desired, during servicing of the model 600 strobe assembly. Each waveform includes the associated measurement point and oscilloscope setting. Waveform amplitudes and frequencies may vary somewhat between units and at various anode voltages.

6-6. Model 600 Strobe Assembly Troubleshooting Chart

a. The following troubleshooting chart is supplied as an aid to locating trouble within the model 600 strobe assembly. The chart lists symptoms,

Model 600 Strobe Assembly Troubleshooting Chart

Step No.	Trouble symptom	Probable trouble	Checks and corrective measures
1	No flash -----	<ul style="list-style-type: none"> a. Low or no anode voltage ----- b. If anode voltage is normal, observe FT1 internally for spark when trigger contacts are shorted. If spark is good, check output circuit. c. Same as (b) above voltage and spark checks, but if spark weak or no spark, check primary circuits. 	<ul style="list-style-type: none"> a. Should be approximately 420 to 480 vdc. Check as shown in figure 6-1. If anode voltage is abnormal check C3A for leakage; using dc power supply, form C3A for one hour at 450 to 480 vdc with a 1K ohm resistor in series with C3A. Then if leakage current exceeds 4.9 volt across the 1K ohm resistor, replace C3A. b. Check connections between T2 secondary and FT1. If good, substitute spare FT1. If trouble continues, replace T2. c. Measure voltage across R8 and R10, each should show approximately 31% of anode voltage (if voltage measures 50% of anode voltage R9 or C4 is shorted). If voltage is correct check C4; meter should swing up then stabilize at approximately 70 vdc, but if meter shows approximately 36% of anode voltage C4 is open. No voltage, T2 primary open.
2	Intermittent flash -----	<ul style="list-style-type: none"> a. Low anode voltage ----- b. Faulty FT1 ----- c. Faulty trigger circuit ----- 	<ul style="list-style-type: none"> a. Check as given in step 1a. b. Check with spare. c. Check as given in step 1c.

Step No.	Trouble symptom	Probable trouble	Checks and corrective measures
3	Operates on ac but not batteries	a. Battery and connections ----- b. Idle mode inoperative ----- c. Q1 defective or R2 open -----	a. Replace battery; check connections. b. Waveform A in figure 6-2 indicates normal idle mode. If abnormal, check S1 and T1 for continuity. c. Check for voltage drop across Q1 collector/emitter. Check R2 value.
4	Operates on battery but idle mode only.	a. Defective R5, R14, C8, or C14 ----- b. Defective SCR1 -----	a. Check waveforms G, I and L of figure 6-2. b. Short SCR1 anode to cathode. If this advances circuit to power mode, check CR2. If diode is good, replace SCR1.
5	Operates on battery but in power mode only.	If this trouble exists, waveforms A and B of figure 6-2 will be abnormal.	Check for idle mode immediately after flashing (charge capacitor fully discharged), indicated by normal waveform A in figure 6-2. If no idle mode, check CR4, R5, C5 and SCR1 for short circuit. If no short circuit is detected, replace SCR1.
6	No cutoff (Q1 conduction in idle mode).	a. VR1 not conducting at 420 to 480 vdc anode voltage. b. VR1 Conducting----- R6 misadjusted-----	a. Check R6, R7, and VR1, if VR1 does not fire regardless of R6 adjustment. b. Replace VR1.
7	Improper voltage at cutoff. (Less than 84% of "cut-on" voltage.)		Adjust R6. If still abnormal, replace VR1.
8	No ac operation -----	a. Switch S1 ----- b. Defective R12, R13, R23, CR3, CR5, CR6, C7, C3.	a. Check continuity of leads and contacts of S1. b. One or more of these components either shorted or open.
9	No charging current -----	a. Defective S1----- b. Battery or battery contacts. ----- c. R12, C9, CR5, CR6, CR7, CR8 -----	a. Replace S1. b. Check for clean, firm contacts. Replace battery. c. One or more of these components open.
10	Low charging current -----	a. C9 Capacitance low ----- b. CR7, CR8, CR12, CR13 -----	a. Should be 2.5 ufd +10cc. b. One or more of these components open.

6-7. Model 700 Strobe Assembly Troubleshooting Chart

The following troubleshooting chart is supplied as an aid to locating trouble within the model 700 strobe assembly. The chart lists symptoms, probable trouble, and checks and corrective measures.

If unit is operated in ac or charge, connect an isolation transformer between the ac line and the ac input before any test equipment is connected to the unit, see figure 6-3.

CAUTION

Model 700 Strobe Assembly Troubleshooting Chart

Step No.	Trouble symptom	Probable trouble	Checks and corrective measures
1	No flash -----	a. Low or no anode voltage -----	a. Should be approximately 425 to 490 vdc. Check as shown in fig. 6-4. If anode voltage is abnor-

Step No.	Trouble symptom	Probable trouble	Checks and corrective measures
		<p>b. If anode voltage is normal, observe FT301 internally for spark when trigger contacts are shorted. If spark is good, check output circuit.</p> <p>c. Same as (b) above voltage and spark checks, but if spark is weak or no spark, check primary circuits.</p>	<p>mal check C303A for leakage; using dc power supply, C303A for one hour at 450 to 490 vdc with a 1K ohm resistor in series with C303A. Then if leakage current exceeds 4.9 ma (4.9 volts across the 1K ohm resistor), replace C303A.</p> <p>b. Check connections between T302 secondary and FT301. If good, substitute spare FT301. If trouble continues replace T302.</p> <p>c. Measure voltage across R308 and R310, each should show approximately 31% of anode voltage (if voltage measures 50% of anode voltage R309 or C304 is shorted). If voltage is correct check C304; meter should swing up then stabilize at approximately 70vdc, but if meter shows approximately 36% of anode voltage C304 is open. No voltage, T302 primary open.</p>
2	Intermittent flash-----	<p>a. Low anode voltage -----</p> <p>b. Faulty FT301-----</p> <p>c. Faulty trigger circuit -----</p>	<p>a. Check as given in step 1a.</p> <p>b. Check with spare.</p> <p>c. Check as given in step 1c.</p>
3	Operates on ac but not batteries -----	<p>a. Battery and connections -----</p> <p>b. Idle mode inoperative -----</p> <p>c. Q301 defective or R3)2 open----</p>	<p>a. Replace battery; check connections.</p> <p>b. Listen for high pitch sound from the oscillator circuit, indicating idle mode is present. If not present check S301 and T301 for continuity.</p> <p>c. Check for voltage drop across Q301 collector to emitter. Check R302 value.</p>
4	Operates on battery but in idle mode only.	<p>a. Defective R305, R314, C308, or CR314.</p> <p>b. Defective SCR301-----</p>	<p>a. Check for short or open.</p> <p>b. Short SCR301 anode to cathode. If this advances circuit to power mode, check CR302. If diode is good replace SCR301.</p>
5	Operates on battery but in power mode only.	Shorted CR304, R305, C:305, or SCR301.	Listen for high pitch sound, presence of idle mode, immediately after flashing. If no idle mode, check for shorted CR304, R305, C305, or SCR301. If no short circuit is detected replace SCR301.
6	No cutoff-----	<p>a. VR301 not firing at 4 5 to 490 vdc anode voltage.</p> <p>b. VR301 conducting -----</p>	<p>a. Check R306, R307, and VR301, if VR301 does not fire regardless of R306 adjustment.</p> <p>b. Replace VR301.</p>
7	Improper voltage at cutoff (less than 80% of cut-on voltage).	R306 misadjusted -----	Adjust R306. If still abnormal, re place VR301.
8	No ac operation-----	<p>a. Defective wall transformer box --</p> <p>b. Defective CR320 or 4336 -----</p>	<p>a. Replace with one known to be good. If transformer box is faulty check CR318 and T304.</p> <p>b. Check and replace as necessary.</p>
9	No battery charger operation -----	Defective S301, CR319, or T304 secondary.	Check and replace as necessary.

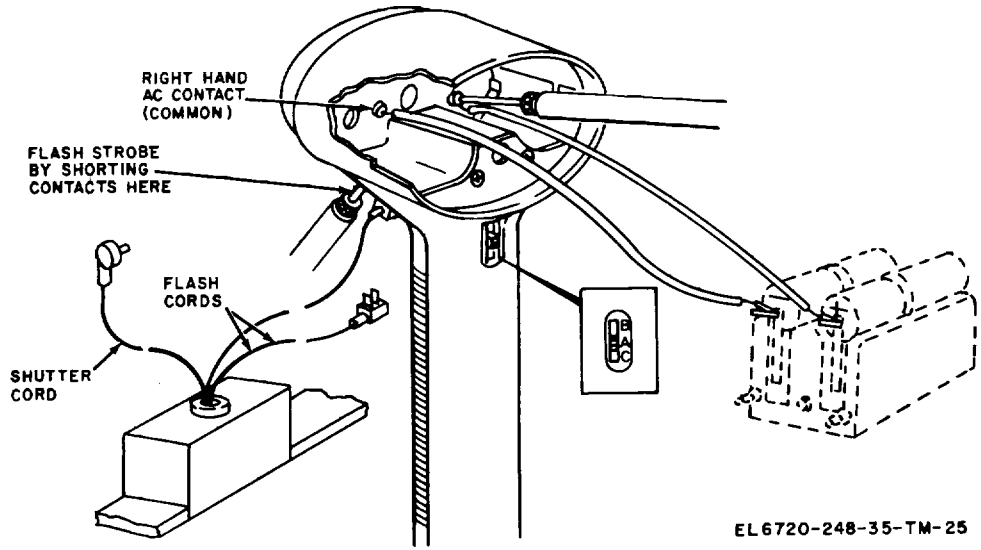

Figure 6-1. Model 600 anode voltage check.

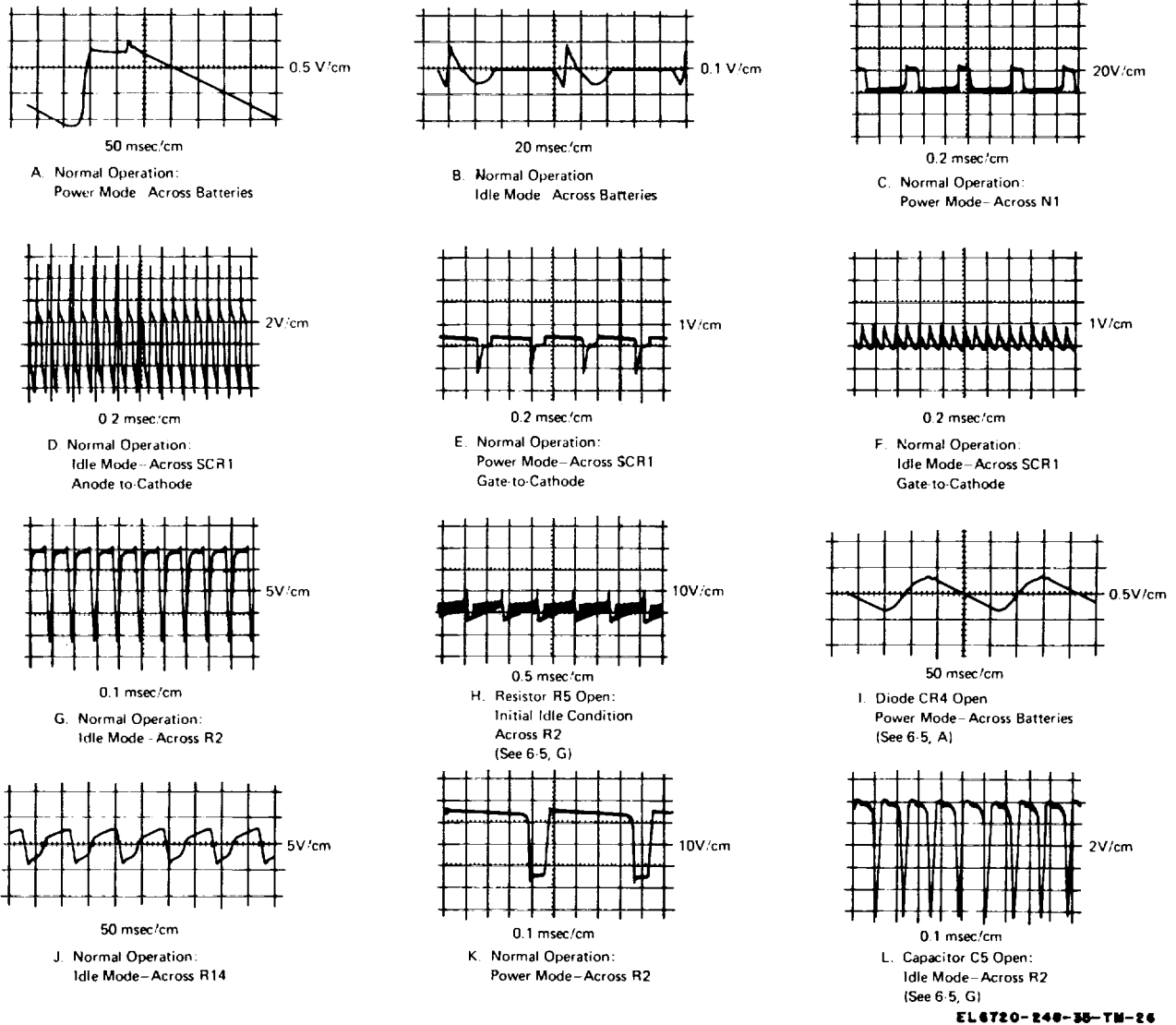

Figure 6-2. Model 600 strobe assembly waveforms.

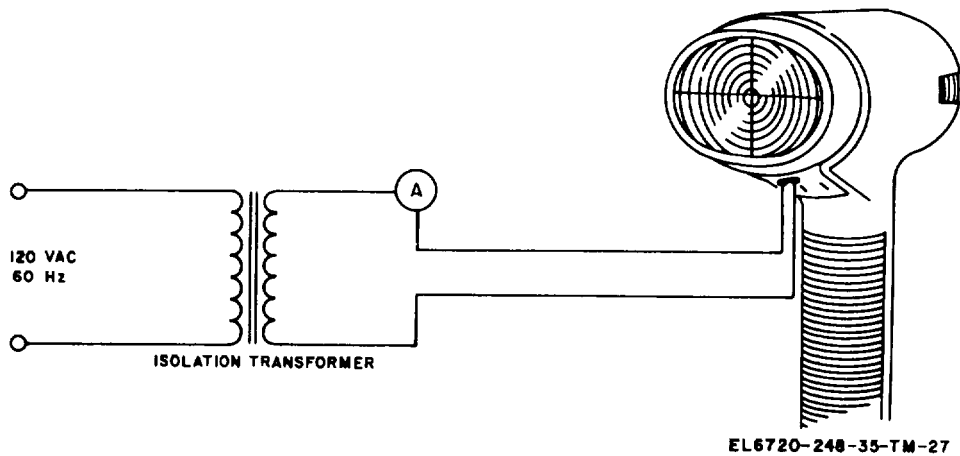

Figure 6-3. AC input test setup.

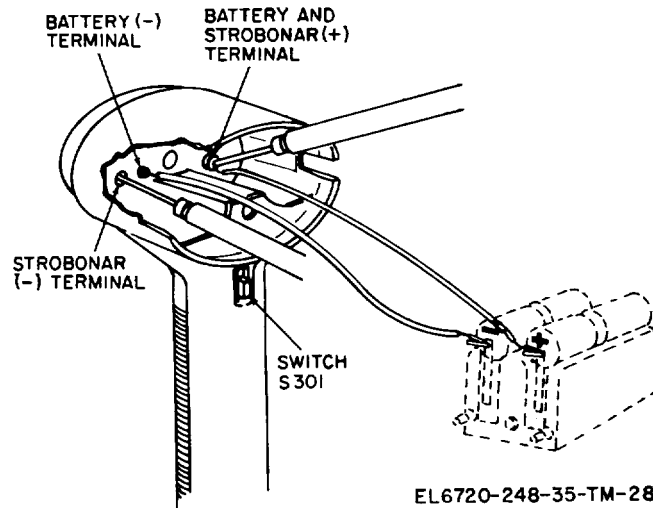

Figure 6-4. Model 700 anode voltage check.

Section III. REPAIR PROCEDURES

6-8. General

This section contains disassembly and assembly procedures for the strobe assemblies. Illustrations in this Section should be consulted during the procedures. Use figure 6-5 (model 600) and 6-8 (model 700) as the guide for maintenance disassembly, which should be sufficient for all troubleshooting, testing, and repair work. It should not be necessary to disassemble to the extent shown in figure 6-6 (model 600) unless the strobe assembly is scheduled for complete rebuild; then, refer to figure 6-7 (model 600) and figures 6-10, 6-11, and 6-12 (model 700) for component locations and wiring diagrams. A simple sketch of the specific area being worked on will augment the illustrations and insure lead dress and layout equivalent to the original. Parts packing density is high and every precaution should be taken when handling the opened assembly to prevent accidental breakage of leads or parts. There is no lead dress requirement that affects the signals or fields.

6-9. Disassembly of Model 600 Strobe Assembly (fig. 6-5)

Disassemble the Model 600 strobe assembly as follows:

a. Depress the two release buttons at the sides of the battery tray assembly (12), and withdraw the assembly from the cap and housing assembly (10).

b. Remove the two screws (11). The various subassemblies are interconnected by cabling. Extract these from the cap and housing assembly (10) and separate them as permitted by cables. Several components are embedded permanently in the handle and are interconnected by cabling and plug-in terminals; do not unplug these terminals now.

c. Loosen two screws (5) to detach the chassis assemblies (7).

d. Remove the shield (6). Unclip the flash tube assembly (3) from the reflector in the reflector housing (4).

6-10. Disassembly of Model 600 Subassemblies (fig. 6-6)

There is no need to do this except for complete rebuild. Proceed as follows:

a. Unplug cable leads connected to capacitor assemblies in the handle, but do not attempt to remove the capacitors.

b. The two black insulators are a press fit (not shown in fig. 6-6).

c. To remove switch (2), file away rivet (1); disconnect and tag leads.

d. To remove circuit cards (4) and (5), unsolder and tag leads. Drill or file out rivet (7). Bend back tabs of chassis (3) to free the circuit cards.

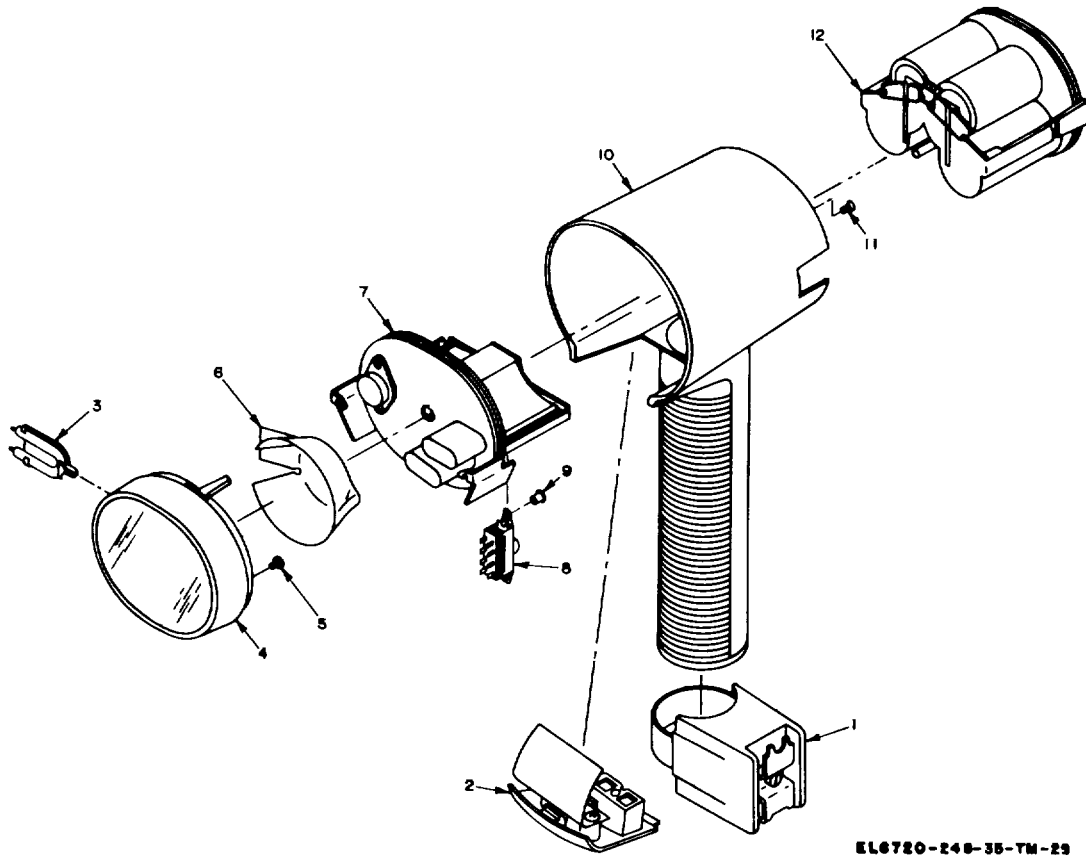

EL6720-248-35-TM-29

- | | | | |
|---|-----------------------------------|----|--------------------------------|
| 1 | Release clamp (MP158) | 7 | Chassis assemblies (CB1) (CB3) |
| 2 | Receptacle housing assembly (A32) | 8 | Slide switch (S1) |
| 3 | Flashtube assembly (FT1) | 9 | Rivet (MP86) |
| 4 | Reflector housing (MP164) | 10 | Cap and housing assembly (A31) |
| 5 | Screw (MP165) | 11 | Screw (MP161) |
| 6 | Shield (MP172) | 12 | Battery tray assembly (A33) |

Figure 6-5. Model 600 strobe assembly, exploded view.

e. Transistor (6) may be removed by unsoldering and drilling out rivet (8).
 f. Disassembly beyond this point can be accomplished by using figure 6-7, wiring diagram and component location.

6-11. Reassembly of Model 600 Subassemblies
 (fig. 6-6)

Reassemble the model 600 subassemblies as follows:

- a. Secure transistor (6) to circuit card (5) with rivet (8).
- b. Insert small circuit card (4) in chassis (3) and bend chassis tabs to secure. Attach cable leads.
- c. Insert large circuit card (5) in chassis (3)

and secure with rivet (7). Bend chassis tabs to secure circuit card. Attach cable leads.

- d. Attach switch (2) with rivet (1).
- e. Install the two black insulators (not shown) and bend tabs to secure.
- f. Plug in cable leads to capacitor assemblies in handle.

6-12. Reassembly of model 600 Strobe Assembly
 (fig. 6-5)

Reassemble model 600 strobe assembly as follows:

- a. Install flash tube assembly (3) in reflector of reflecting housing (4). Cover reflector with shield (6).
- b. Attach reflector housing (4) to chassis assemblies (7) and secure with two screws (5).

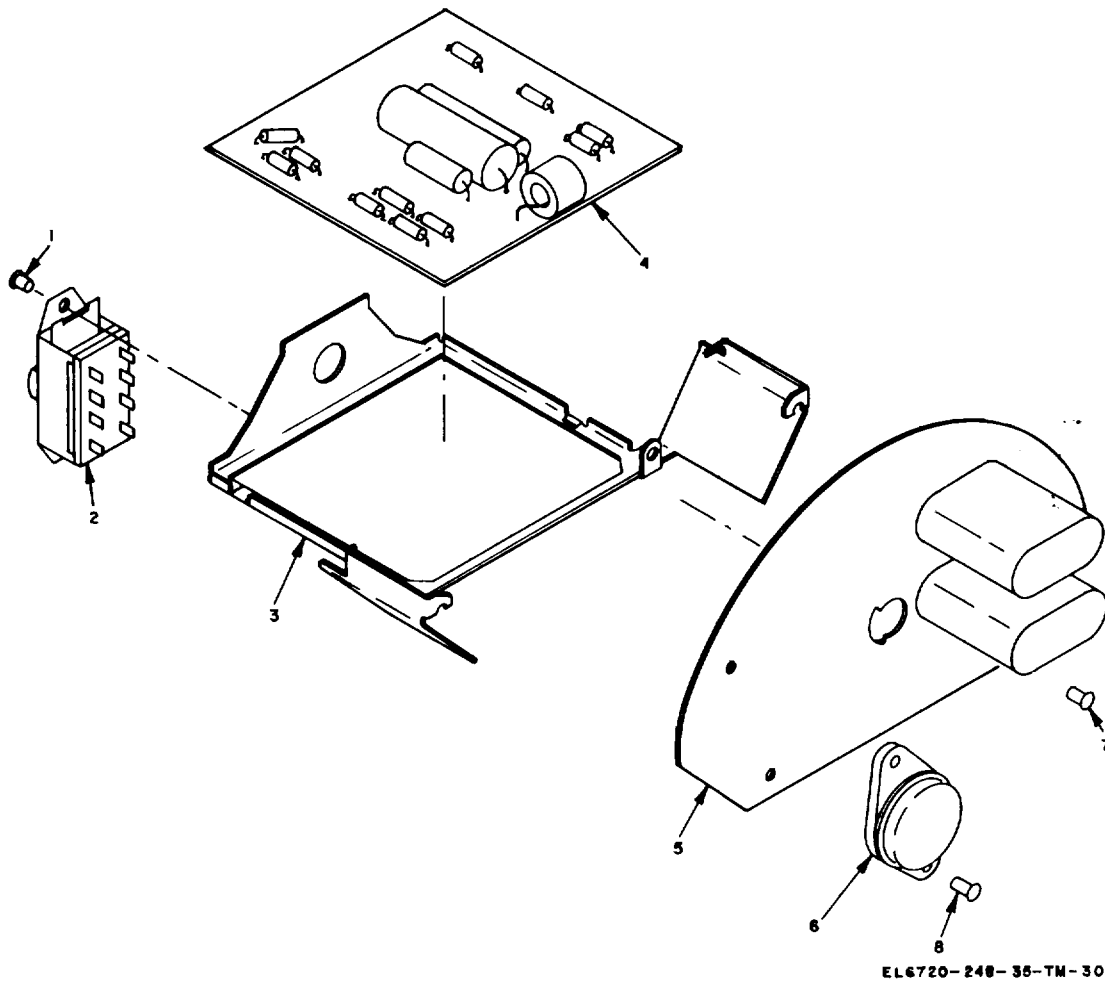

- | | | | |
|---|-----------------------------------|---|-----------------------------------|
| 1 | Rivet (MP86) | 5 | Circuit card assembly No. 1 (CB1) |
| 2 | Slide switch (S1) | 6 | Transistor (Q1) |
| 3 | Chassis | 7 | Rivet (MP175) |
| 4 | Circuit card assembly No. 3 (CB3) | 8 | Rivet (MP176) |

Figure 6-6. Model 600 circuit card assembly, exploded view.

c. Replace subassemblies in cap and housing assembly (10) and secure with two screws (11).

d. Push the battery tray assembly (12) into the cap and housing assembly (10) until it latches in place.

6-13. Disassembly of Model 700 Strobe Assembly
(fig. 6-8)

Disassemble the model 700 strobe assembly as follows:

a. Depress the two release buttons at the sides of the battery tray assembly (1) and withdraw the assembly from the capacitor and housing assembly (2).

b. Remove the two screws (3). The various subassemblies are interconnected by cabling. Extract these from the capacitor and housing assembly (2) and separate them as much as permitted by the cables. Several components are embedded permanently in the handle and are interconnected by cabling and plug-in terminals; do not unplug these terminals now.

c. Remove three screws (4) and slide the chassis (5) back off the chassis assembly (6); separate the reflector (7), lens (8), and reflector housing (9).

d. Unclip the flash tube assembly (10) from the reflector (7).

e. Remove screw (13) and separate switch (14) from chassis (5).

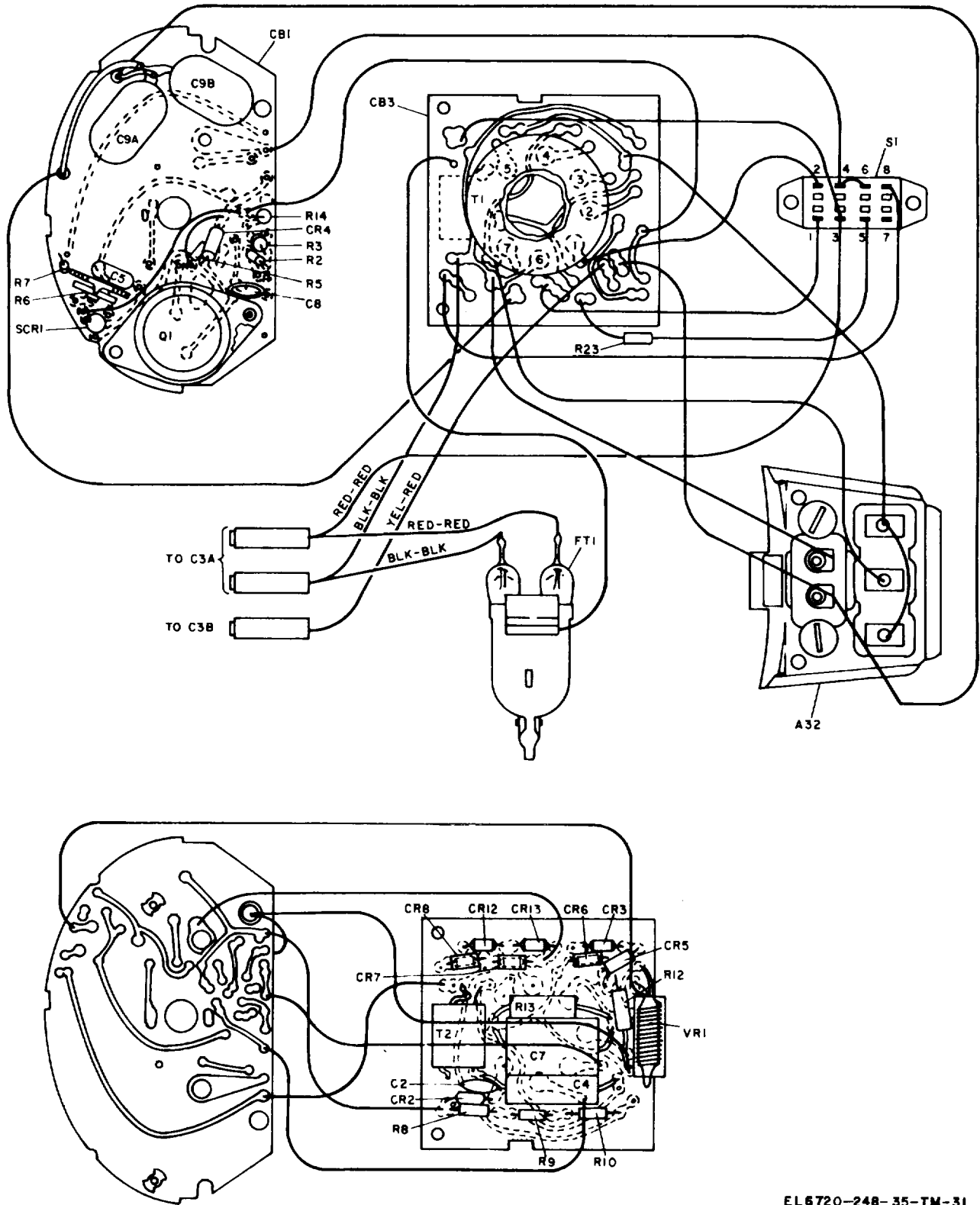
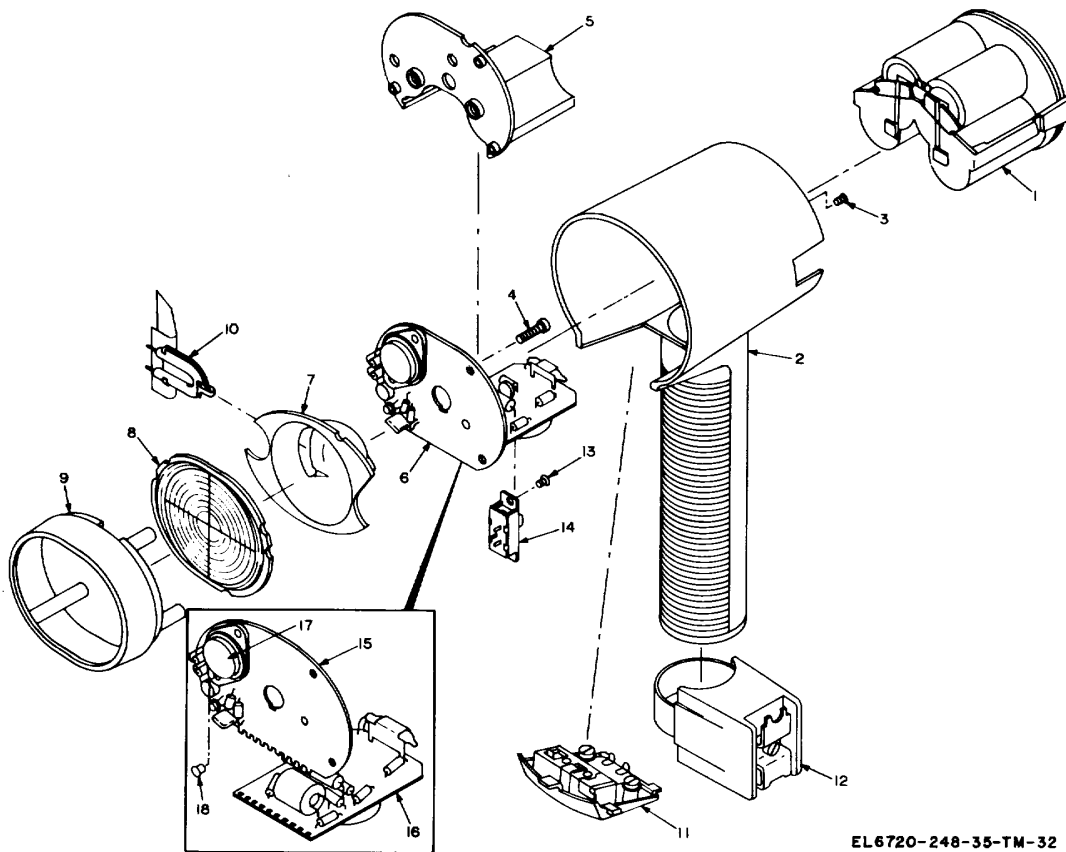

Figure 6-7. Model 600 strobe assembly, wiring diagram.



EL6720-248-35-TM-32

- | | | | |
|---|--------------------------------------|----|-------------------------------------|
| 1 | Battery tray assembly (A45) | 10 | Flash tube assembly (FT301) |
| 2 | Capacitor and housing assembly (A42) | 11 | Receptacle assembly (A44) |
| 3 | Screw (MP234) | 12 | Release clamp (MP228) |
| 4 | Screw (MP236) | 13 | Screw (MP245) |
| 5 | Chassis (MP235) | 14 | Switch (S301) |
| 6 | Chassis assembly (A43) | 15 | Circuit card assembly No. 1 (CB301) |
| 7 | Reflector (MP249) | 16 | Circuit card assembly No. 3 (CB303) |
| 8 | Lens (MP248) | 17 | Transistor (Q301) |
| 9 | Reflector housing (MP250) | 18 | Rivet (MP239) |

Figure 6-8. Model 700 strobe assembly, exploded view.

f. To disassemble ac power cord assembly (fig. 6-9), remove two screws (1) and cover (2) from base (3). Separate transformer (4) and base (3) as much as cabling will permit.

6-14. Disassembly of Model 700 Subassemblies
(fig. 6-8)

There is no need to do this except for complete rebuild. Proceed as follows:

a. Unplug cable leads connected to capacitor assemblies in the handle, but do not attempt to remove capacitors.

b. Separate circuit card (15) and circuit card (16) by unsoldering contacts in 10 places.

c. Transistor (17) may be removed by unsoldering and drilling out rivet (18).

d. Disassembly beyond this point can be accomplished by using figure 6-10, wiring diagram, and figures 6-11 and 6-12 for component location.

6-15. Reassembly of Model 700 Subassemblies
(fig. 6-8)

Reassemble model 700 subassemblies as follows:

- a. Secure transistor (17) to circuit card (15) with rivet (18).
- b. Set the tongues of circuit card (15) in the slots of the circuit card (16) and solder, 10 places.
- c. Plug in cable leads to capacitor assemblies in the capacitor and housing assembly (2).

6-16. Reassembly of Model 700 Strobe Assembly
(fig. 6-8)

Reassemble model 700 strobe assembly as follows:

- a. Reassemble ac power cord assembly (fig. 6-9), by replacing transformer (4), circuit board (6), diode (7), and power cord (5) in the cover (2). Secure cover (2) to the base (3) with two screws (1).

- b. Install flashtube assembly (10) in the reflector (7).
- c. Slide chassis (5) on chassis assembly (6). Position lens (18) and reflector (7) in reflector housing (9) and secure reflector housing (9) to chassis assembly (6) with three screws (4).
- d. Secure switch (14) to chassis (5) with screw (13).
- e. Replace subassemblies in capacitor and housing assembly (2) and secure with two screws (3).
- f. Push the battery tray assembly (1) into the capacitor and housing assembly (2) until it latches in place.

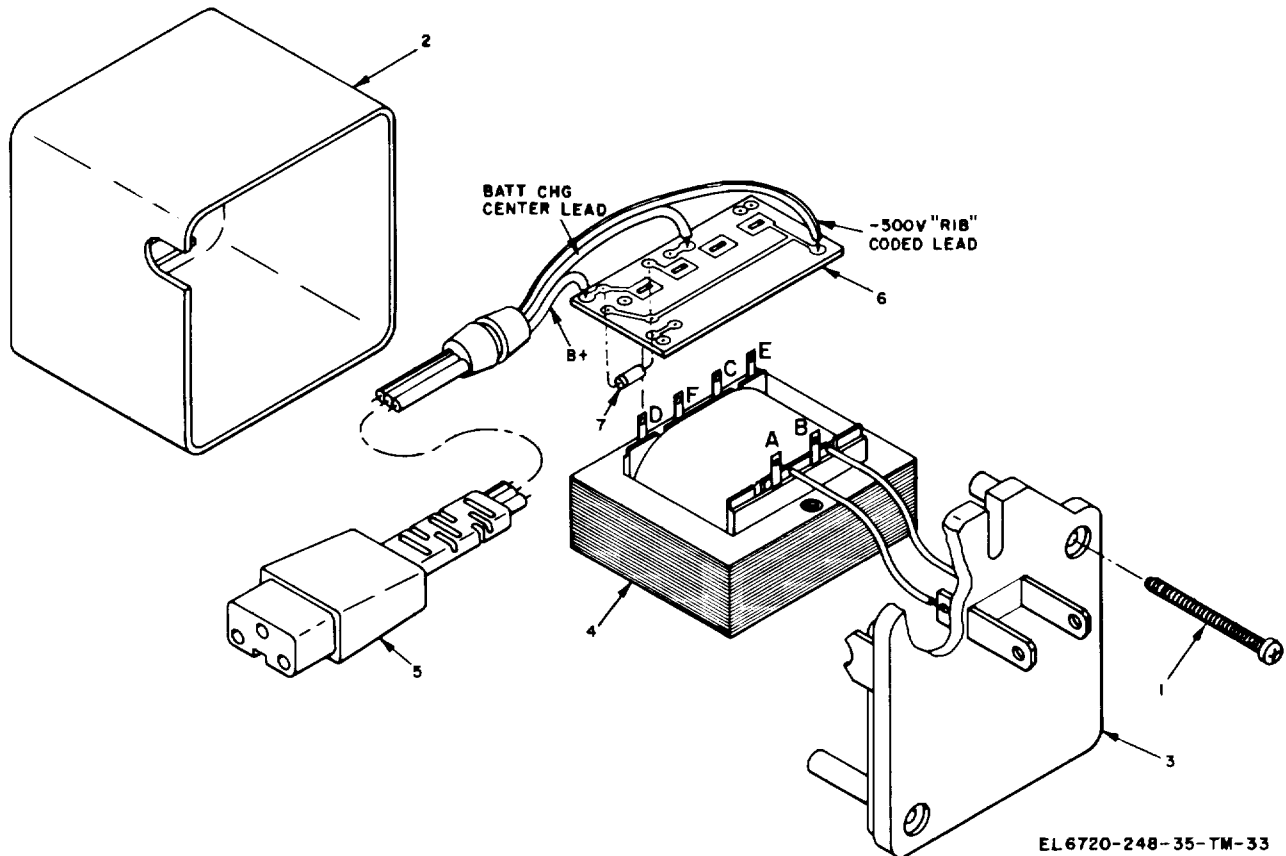

EL 6720-248-35-TM-33

- | | | | |
|---|--------------------|---|-----------------------|
| 1 | Screw (MP233) | 5 | Power cord (MP231) |
| 2 | Cover (MP232) | 6 | Circuit board (MP230) |
| 3 | Base (MP229) | 7 | Diode (CR318) |
| 4 | Transformer (T304) | | |

Figure 6-9. Model 700 ac power cord assembly.

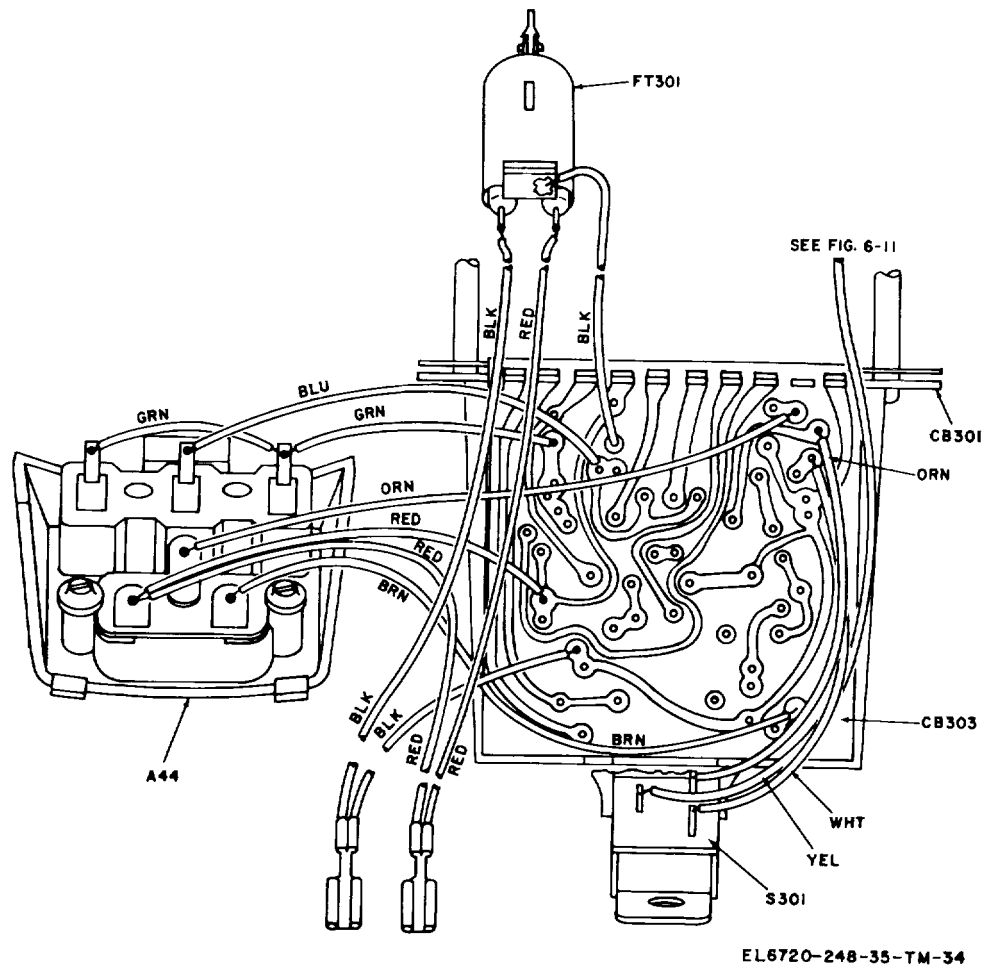

Figure 6-10. Model 700 strobe assembly, wiring diagram.

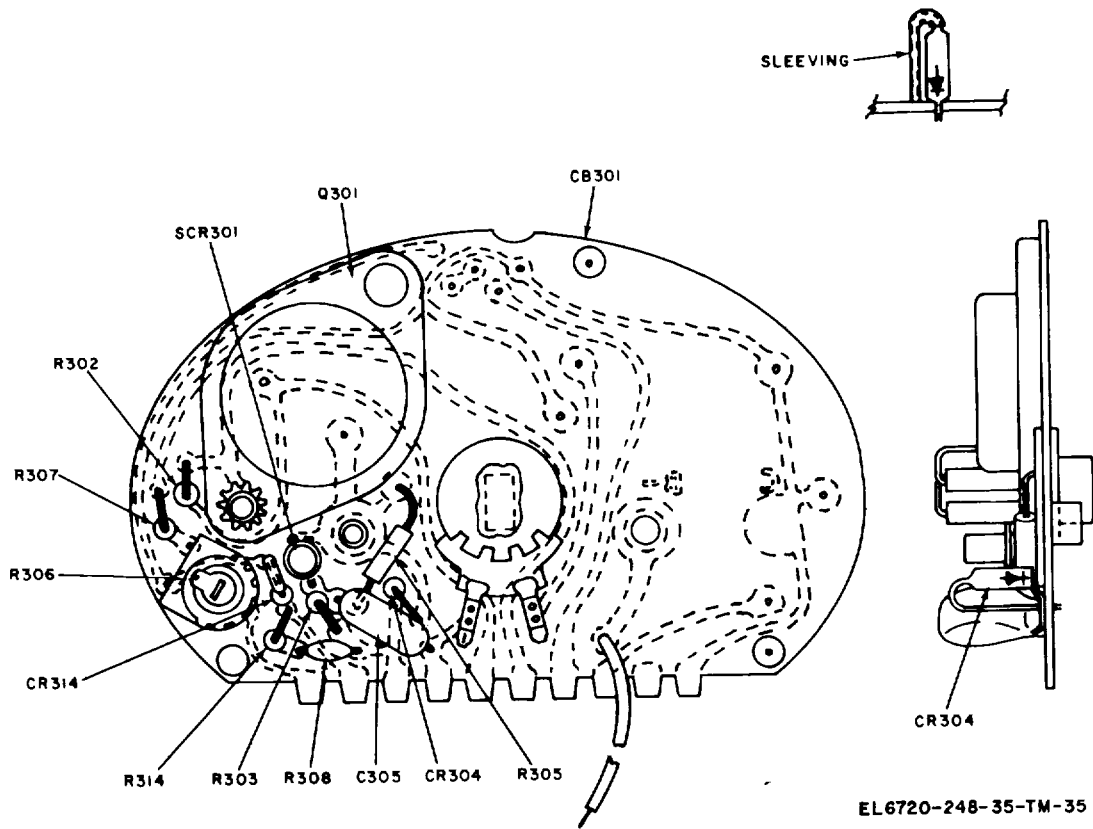

Figure 6-11. Model 700 circuit card assembly No. 1.

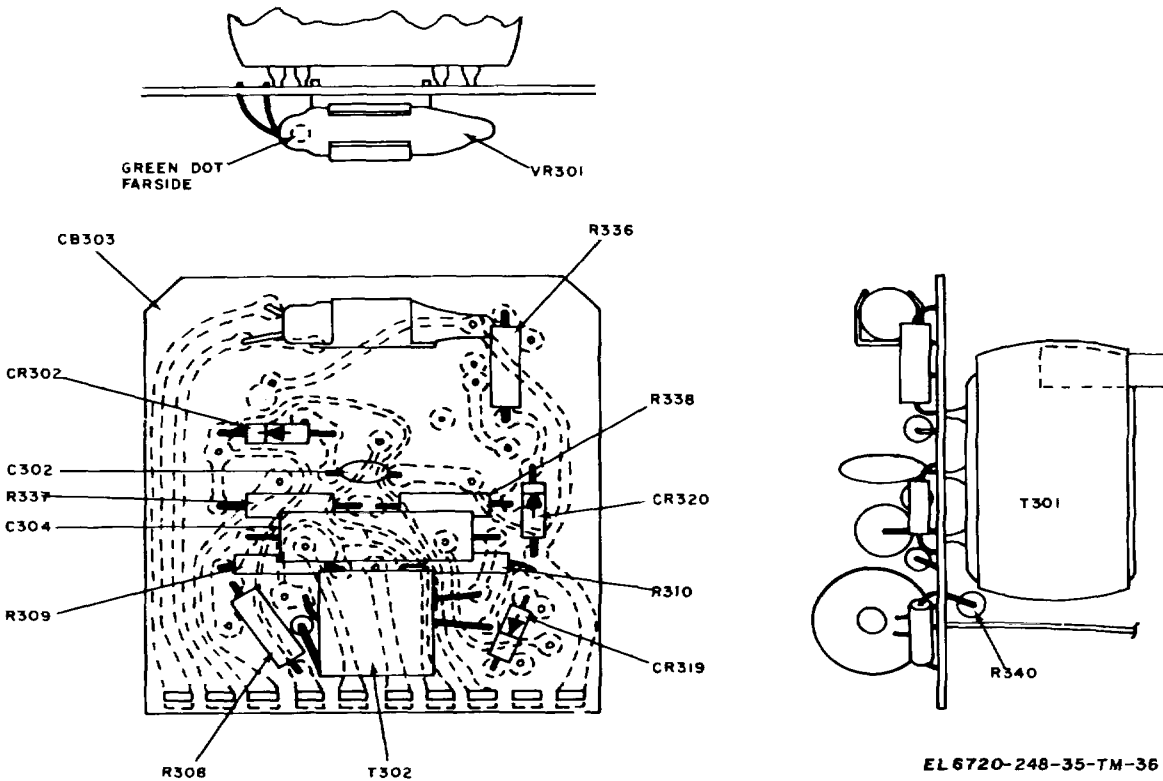

Figure 6-12. Model 700 circuit card assembly No. 2.

Section IV. TESTING

WARNING

Be extremely careful when troubleshooting the strobe assembly. Potentials in excess of 500 volts are present. Be especially careful when handling the cap and housing assembly. Capacitors in the handle retain a lethal charge. Use insulated test probes when measuring voltages. Before disassembling the strobe assembly, comply with the instructions in the warning notice at the beginning of this manual.

6-17. General

Testing procedures are given for an operational checkout of the strobe assemblies following repair. Also, they may be used in lieu of troubleshooting routines in cases where the problem is an elementary one; discovered during the preliminary inspection.

6-18. Tools, Materials, and Test Equipment Required for Strobe Assembly Testing

The following tools, materials, and test equipment are required for strobe assembly testing:

a. *Tools.* No special tools are required.

b. *Materials.* None.

c. *Test Equipment.*

- (1) Multimeter TS-352/U.
- (2) AC ammeter
- (3) Light meter.
- (4) Isolation transformer.
- (5) Four Ni-Cad "D" batteries (fully charged).
- (6) Stopwatch

6-19. Model 600 Strobe Assembly Tests

a. *Materials.* None.

b. *Test Connections or Conditions.*

(1) Storage capacitor C3A is contained in the cap and housing assembly (10, fig. 6-5). Complete formation of this capacitor requires 1 hour of strobe assembly operation from the ac line voltage. To accelerate forming, flash the strobe assembly every 2 or 3 minutes during the forming period.

(2) Voltage measurements are made with the test setup shown in figure 6-1.

(3) Current measurements are made with the test setup shown in figure 6-3.

(4) The battery assembly that accompanies the strobe assembly must be in full charge.

c. Procedure.

		Control settings			
Step No.	Test equipment	Equipment under test		Test procedure	Performance standard
1	Multimeter: Refer to para 6-19b (2).	Strobe assembly function switch set to B.		a. Measure and record cutoff voltage (C3A fully charged). b. Flash strobe and measure cut-on voltage (ready light illumination).	a. Meter indicates 450 +30 vdc. b. Meter indicates no less than 84% of cutoff voltage recorded in step 1a.
2	Multimeter: Refer to para 6-19b (2). Stopwatch: Set to 0.	Strobe assembly function switch set to B.		Flash strobe and start stopwatch simultaneously. Measure cutoff voltage. Stop the watch when the cutoff voltage is reached.	Recycle time to cutoff is less than 15 seconds.
3	Multimeter: Refer to para 6-19b (2)	Strobe assembly function switch set to A.		Flash strobe and measure cutoff voltage.	Meter indicates 420 ±20 vdc.
4	Transformer and ammeter: Refer to para 6-19b (3).	Strobe assembly function switch set to A.		Flash strobe and start the stop watch simultaneously. After 30 seconds note ammeter indication.	Meter indicates 15 ±3 ma 30 seconds after flashing.
5	Light meter: Refer to para 6-19b (3).	Strobe assembly function switch set to B.		Align light meter lens with strobe lens at a distance of 4 feet. Short shutter cord contacts, to flash strobe and note light meter indication.	Light meter indicates a minimum of 95 lumen-seconds per square foot.
6	Lens uncovered. Transformer and ammeter: Refer to para 6-19b (3).	Strobe assembly function switch set to C.		After 16 hours note ammeter indication.	Meter indicates between 80 and 125 ma.

6-20. Model 700 Strobe Assembly Tests

a. *Materials.* None.

b. *Test Connections or Conditions.*

(1) Storage capacitor C303A is contained in the capacitor and housing assembly (2, fig. 6-8) Complete formation of this capacitor requires 1 hour of strobe assembly operation from the ac line voltage. To accelerate forming, flash the strobe assembly every 2 or 3

minutes during the forming period.

(2) Voltage measurements are made with the test setup shown in figure 6-4.

(3) Current measurements are made with the test setup shown in figure 6-3.

(4) The battery assembly that accompanies the strobe assembly must be at full charge.

Step No.	Control settings		Test procedure	Performance standard
	Test equipment	Equipment under test		
1	Multimeter: Refer to para 6-20b (2).	Strobe assembly functional switch set to ON..	a. Measure and record cut-off voltage. (C303A fully Charged). b. Flash strobe and measure cut-on voltage. (ready light illumination).	a. Meter indicates 460 :30 vdc. b. Meter indicates no less than 80% of cutoff voltage recorded in step 1a.
2	Multimeter: Refer to para 6-20b (2). Stopwatch: Set to 0.	Strobe assembly function switch set to ON.	Flash strobe and start the stopwatch simultaneously. Measure cutoff voltage. Stop the watch when the cutoff voltage recorded in step 1a is reached.	Recycle time to cutoff is less than 15 seconds.
3	Multimeter: Refer to para 6-20b (2). Transformer and ammeter: Refer to para 6-20b (3).	Strobe assembly function switch set to OFF.	Flash strobe and measure cutoff voltage.	Meter indicates no less than 80% of the cutoff voltage recorded in step 1a.
4	Multimeter: Refer to para 6-20b (2). Transformer and ammeter: Refer to para 6-20b (3). Stopwatch: Set to 0.	Strobe assembly function switch set to OFF.	Flash strobe and start the stopwatch simultaneously. Stop the watch when the cutoff voltage measured in step 3 is reached.	Recycle time is 18 seconds or less.
5	Light meter: Lens uncovered.	Strobe assembly function switch set to ON.	Align light meter lens with strobe lens at a distance of 4 feet. Flash strobe and note light meter indication.	Light meter indicates between 90 and 150 lumen-seconds per square foot.

CHAPTER 7 DEPOT OVERHAUL STANDARDS

Section I. GENERAL

7-1. General

Testing procedures are prepared for use by depot maintenance organizations responsible for depot maintenance of equipment to determine the acceptability of repaired equipment. These procedures set forth specific requirements that repaired equipment must meet before it is returned to the using organization or to stock.

7-2. Scope of Depot Overhaul Standards

a. Section II lists all test equipment necessary to perform complete testing of the camera set; and lists all

required tests, with a brief description of the purpose of each test. Section III contains the test procedures including the test equipment required for each specific test and the test conditions and connections to perform the test.

b. The complete technical manual for the camera set consists of TM 11-6720-248-12 and this manual. After the camera set has been repaired, refer to TM 11-6720-248-12 for procedures to set up and operate the camera set. The troubleshooting procedures and disassembly and assembly procedures may be found in chapters 3, 4, 5, and 6 of this Manual.

Section II. TEST EQUIPMENT AND TESTS

7-3. General

This section lists the test equipment, tools, and materials required for an overall camera set test. The facility requirements are explained; and finally a list of all tests with a general description of the performance standards each test is required to meet.

7-4. Test Equipment, Tools, and Materials

a. Test Equipment.

- (1) Multimeter, TS-505, FSN 6625-243-0562 (TM 11-6625-203-12) or equivalent.
- (2) Watch, Stop FSN 6645-719-8670.
- (3) Lightmeter, Honeywell TE 611, EGG model 580-il, or equivalent.
- (4) Ac Ammeter, 0.1-amp range, @55% accuracy.
- (5) Analyzer, Motion, LS-76, FSN 6780-062-4542.
- (6) Focusing screen (ground glass).
- (7) Type 53 Lamp, 14.4 volts at 120 ma, with lamp socket and two probe leads.

b. *Tools.* Toolkit, TK77/GF FSN 5480-752-9068.

c. Materials.

- (1) Polaroid-Land Film, black and white, Type 107.
- (2) Polaroid-Land Film, color, Type 108.
- (3) National Bureau of Standards Resolution Chart.

d. Other Equipment.

- (1) Isolation Transformer Triad N-53 M, or equivalent.
- (2) Four Ni-Cad "D" Cells (fully charged).
- (3) No. 1 photofloodlamp and reflector.

7-5. Test Facility

Testing of the camera set requires no special facilities; the only requirement being access to 115 vac, 60-Hz line voltage.

7-6. Tests

a. *General.* The camera set is equipped with either model 600 or with model 700 strobe assemblies and an external battery charger. When testing the strobe assemblies it is important to note which model is being tested so the appropriate test procedure can be followed. Camera set testing is divided into three major areas: (1) strobe

assemblies, (2) camera set, and (3) external battery charger.

b. Model 600 Strobe Assembly Tests.

(1) *Anode voltage test (battery operation).*

Measures the cutoff voltage (fully charged condition) of the storage capacitor, and the cut-on voltage (ready lamp illumination) of the storage capacitor.

(2) *Recycle time (battery operation).*

Measures the time required to fully charge the storage capacitor after the strobe is flashed.

(3) *Anode voltage test (ac operation).*

Measures anode voltage to insure it builds up within required time after flashing for ac operation.

(4) *Recycle time (ac operation).*

Measure current consumption to insure strobe is ready to flash within specific time.

(5) *Battery charge test.*

Measure current consumption to insure batteries are fully charged after required charging period.

c. Model 700 Strobe Assembly Tests.

(1) *Anode voltage test (battery operation).*

Measures the cutoff voltage (fully charged condition) of the storage capacitor, and the cut-on voltage (ready lamp illumination) of the storage capacitor.

(2) *Recycle time (battery operation).*

Measures the time required to fully charge the storage capacitor after the strobe is flashed.

(3) *Anode voltage test (ac operation).*

Measures the anode voltage to insure it builds up to required voltage for ac operation.

(4) *Recycle time (ac operation).*

Measures the time required to build up charge between flashes.

d. Camera Assembly Tests.

(1) *Lens and shutter assembly, shutter speed and flash synchronization tests.* Measures shutter speed and verifies that the flash is synchronized with shutter opening.

(2) *Lens and shutter focus test.* Verifies that the focal length can be set to insure an in focus picture.

(3) *Light leakage test.* Tests the camera assembly against the possibility of light leaks on the film.

(4) *Overall camera set tests.* Verifies operation of the camera set; including tripod, titleboard, and stereoscopic attachment functions as well as the camera set's ability to take quality pictures, black and white or color, with or without flash.

e. External Battery Charger Tests. Verifies the external battery charger is capable of supplying a charging current at all charging positions for a specific amount of time.

Section III. STROBE ASSEMBLY TESTS

WARNING

Be extremely careful when testing the strobe assemblies. Capacitors in the handle retain a lethal charge, potentials in excess of 500 volts are present. Use insulated test probes when measuring voltages.

7-7. Model 600 Strobe Assembly Test Procedure

a. Test Equipment and Materials.

(1) Multimeter, TS-505, FSN 6625-243-

0562.

(2) AC ammeter.

(3) Light meter.

(4) Isolation transformer.

(5) Four Ni-Cad "D" cells (fully charged).

b. Test Connections and Conditions.

(1) Complete formation of the storage capacitor, contained in the strobe assembly handle, is

required prior to performing the test procedures. Complete formation of this capacitor requires 1 hour of strobe assembly operation from the ac line voltage. To accelerate forming, flash the strobe assembly every 2 or 3 minutes during the forming period.

(2) The battery assembly that accompanies the strobe assembly must be at full charge.

(3) Voltage measurements are made with the test setup shown in figure 6-1.

(4) Ac operation current measurements are made with the test setup shown in figure 6-3.

c. Procedure.

Step No.	Control settings		Test procedure	Performance standard
	Test equipment	Equipment under test		
1	Multimeter: Refer to para 7-7b (3).	Strobe assembly function switch set to B.	Refer to para 7-6b(1). a. Measure and record cutoff voltage. b. Flash strobe to extinguish ready-light then measure cut-on voltage (light on).	a. Meter indicates 450 ±30 vdc. b. Meter indicates no less than 84% of cutoff voltage recorded in step 1a.
2	Multimeter: Refer to para 7-7b (3). Stopwatch: Set to 0.	Strobe assembly function switch set to B.	Refer to para 7-6b(3) Short shutter cord contacts, to flash strobe, and start stopwatch simultaneously. Measure cutoff voltage. Stop the watch when the cutoff voltage recorded in step 1a is reached.	Recycle time to cutoff is less than 15 seconds
3	Multimeter: Refer to para 7-7b (3). Transformer and ammeter: Refer to para 7-7b (4).	Strobe assembly function switch set to A.	Refer to para 7-6b(s). Short shutter cord contacts, to flash strobe, and measure cutoff voltage.	Meter indicates 420 ±20 vdc.
4	Transformer and ammeter: Refer to para 7-7b (4).	Strobe assembly set to A -----	Short shutter cord contacts, to flash strobe, and start stopwatch simultaneously. After 30 seconds note ammeter indication.	Meter indicates 15 ±3ma 30 seconds after flashing.
5	Light meter: Lens uncovered.	Strobe assembly function switch set to B.	Refer to para 7-6b(5). Align light meter lens with strobe lens at a distance of 4 feet. Short shutter cord contacts, to flash strobe and note light meter indication.	Light meter indicates a minimum of 95 lumen-seconds per square foot.
6	Transformer and ammeter: Refer to para 7-7b (4).	Strobe assembly function switch set to C.	Refer to para 7-6b (5). After 16 hours note ammeter indication.	Meter indicates between 80 and 125 ma.

7-8. Model 700 Strobe Assembly Test Procedure

a. Test Equipment and Materials.

- (1) Multimeter.
- (2) Ac ammeter.
- (3) Light meter.
- (4) Isolation transformer.
- (5) Four Ni-Cad "D" cells (fully charged).

b. Test Connections and Conditions.

(1) Complete formation of the storage capacitor, contained in the strobe assembly handle, is

required prior to performing the test procedures. Complete formation of this capacitor requires 1 hour of strobe assembly operation from the ac line voltage. To accelerate forming, flash the strobe assembly every 2 or 3 minutes during the forming period.

(2) The battery assembly that accompanies the strobe assembly must be at full charge.

(3) Voltage measurements are made with the test setup shown in figure 6-4.

(4) Ac operation measurements are made with the test setup shown in figure 6-3.

c. Procedure.

Step No.	Control settings		Test procedure	Performance standard
	Test equipment	Equipment under test		
1	Multimeter: Refer to para 7-7b (3).	Strobe assembly function switch set to B.	Refer to para 7-6b(1). a. Measure and record cutoff voltage. b. Flash strobe to extinguish ready-light then measure cut-on voltage (light on).	a. Meter indicates 450 :30 vdc. b. Meter indicates no less than 84% of cutoff voltage recorded in step 1a.
2	Multimeter: Refer to para 7-7b (3). Stopwatch: Set to 0.	Strobe assembly function switch set to B.	Refer to para 7-6b(3) Short shutter cord contacts, to flash strobe, and start stopwatch simultaneously. Measure cutoff voltage. Stop the watch when the cutoff voltage recorded in step 1a is reached.	Recycle time to cutoff is less than 15 seconds
3	Multimeter: Refer to para 7-7b (3). Transformer and ammeter: Refer to para 7-7b (4).	Strobe assembly function switch set to A.	Refer to para 7-6b(s). Short shutter cord contacts, to flash strobe, and measure cutoff voltage.	Meter indicates 420 ±20 vdc.
4	Transformer and ammeter: Refer to para 7-7b (4).	Strobe assembly set to A-----	Short shutter cord contacts, to flash strobe, and start stopwatch simultaneously. After 30 seconds note ammeter indication.	Meter indicates 15 -3ma 30 seconds after flashing.
5	Light meter: Lens uncovered.	Strobe assembly function switch set to B.	Refer to para 7-6b(5). Align light meter lens with strobe lens at a distance of 4 feet. Short shutter cord contacts, to flash strobe and note light meter indication.	Light meter indicates a minimum of 95 lumen-seconds per square foot.
6	Transformer and ammeter: Refer to para 7-7b (4).	Strobe assembly function switch set to C.	Refer to para 7-6b (5). After 16 hours note ammeter indication.	Meter indicates between 80 and 125 ma.

7-8. Model 700 Strobe Assembly Test Procedure

a. Test Equipment and Materials.

- (1) Multimeter.
- (2) Ac ammeter.
- (3) Light meter.
- (4) Isolation transformer.
- (5) Four Ni-Cad "D" cells (fully charged).

b. Test Connections and Conditions.

(1) Complete formation of the storage capacitor, contained in the strobe assembly handle, is required prior to performing the test procedures.

Complete formation of this capacitor requires 1 hour of strobe assembly operation from the ac line voltage. To accelerate forming, flash the strobe assembly every 2 or 3 minutes during the forming period.

(2) The battery assembly that accompanies the strobe assembly must be at full charge.

(3) Voltage measurements are made with the test setup shown in figure 6-4.

(4) Ac operation measurements are made with the test setup shown in figure 6-3.

c. Procedure.

Step No.	Control settings		Test procedure	Performance standard
	Test equipment	Equipment under test		
1	Multimeter: Refer to para 7-8b (8).	Strobe assembly function switch set to ON.	Refer to para 7-6c(1). a. Measure and record cutoff voltage. b. Flash strobe to extinguish ready light, then measure cut-on voltage (light on).	a. Meter indicates 460 :30 vdc. b. Meter indicates no less than 80% of cutoff voltage recorded in step 1a.
2	Multimeter: Refer to par 7-86 (3). Stopwatch: Set to 0.	Strobe assembly function switch set to ON.	Refer to para 7-6c(2). Flash strobe and start the stopwatch simultaneously. Measure cutoff voltage. Stop the watch when the cutoff voltage recorded in step 1a is reached.	Recycle time to cutoff is less than 15 seconds.
3	Multimeter: Refer to para 7-8b (3). Transformer and ammeter: Refer to para 7-8b (4).	Strobe assembly function switch set to OFF.	Refer to para 7-6c(3). Flash strobe and measure cutoff voltage.	Meter Indicates no less than 80% of the cutoff voltage recorded in step 1a.
4	Multimeter: Refer to para 7-8b (3). Transformer and ammeter: Refer to para 7-8b (4). Stopwatch: Set to 0.	Strobe assembly function switch set to OFF.	Refer to para 7-6c(4). Flash strobe and start stopwatch simultaneously. Stop the watch when the cutoff voltage measured in step 3 is reached.	Recycle time is 18 seconds or less.
5	Light meter: Lens uncovered.	Strobe assembly function switch set to ON.	Refer to para 7-6c(4). Align light meter lens with strobe lens at a distance of 4 feet. Flash strobe and note light meter indication.	Light meter indicates between 90 and 150 lumen-seconds per square foot.

Section IV. CAMERA ASSEMBLY TESTS

7-9. Camera Assembly Test Procedure

- a. *Test Equipment and Materials.*
- (1) Analyzer, Motion, L-76.
 - (2) Focusing screen (ground glass).
 - (3) No. 1 photofloodlamp and reflector.
 - (4) National Bureau of Standards Resolution Chart.
 - (5) Polaroid-Land Film, black and white, Type 107.
 - (6) Polaroid-Land Film, color, Type 108.

b. *Test Connections and Conditions.*

(1) Shutter speed and flash synchronization can best be performed with the lens and shutter assembly installed on the adjustable cell. Set up the motion analyzer and lens and shutter assembly as

shown in figure 52. Place tolerance chart over motion analyzer screen and insure lens and shutter assembly is centered over the opening in the photocell housing.

(2) Verify motion analyzer has been properly calibrated, and switches positioned as follows:

Switch	Position
POWER-----	ON
SR-----	S
FUNCTION-----	A
TIME IN SECONDS-----	.0468
Photocell lamp-----	Low

(3) After testing in conditions (1) and (2) above replace adjustable cell, but do not tighten set screws. Completely assemble camera set as

Step No.	Control settings		Test procedure	Performance standard
	Test equipment	Equipment under test		
7	None -----	None -----	<p><i>d.</i> Remove and reattach camera assembly to tripod.</p> <p><i>e.</i> Open and close tripod and operate telescoping inner tube with camera assembly removed.</p> <p><i>a.</i> Check back assembly doors, hinges, latches, and all interior assemblies. No bent or misaligned surfaces and no burrs. No damage to paint finish.</p> <p><i>b.</i> Check all external surfaces for dents, damage to paint finish, or to labels and printed instructions.</p>	<p><i>d.</i> Setscrew works properly; camera assembly does not bind on tripod.</p> <p><i>e.</i> There is no binding of legs or leg links or clamps. Counterbalance works smoothly; tripod stands firm.</p> <p><i>a.</i> Doors operate smoothly without warp or hinge bind. Door latches secure doors correctly.</p> <p><i>b.</i> No damage to fabric covering. Labels and instructions intact and legible.</p>
8	None -----	<p>Iris diaphragm control lever: 4.5; shutter speed control: 30. Disconnect shutter cord from jack on lens and shutter assembly.</p> <p>Change shutter speed to 60 and rotate back assembly.</p> <p>Change shutter speed to 125 and rotate back assembly.</p> <p>Change shutter speed to T and rotate back assembly.</p> <p>Change shutter speed to B and rotate back assembly.</p>	<p><i>a.</i> Open back assembly and view lens from rear while tripping shutter.</p> <p><i>b.</i> Attempt to trip shutter again.</p> <p><i>c.</i> Rotate back assembly 180 degrees clockwise; then attempt to trip shutter.</p> <p><i>a.</i> View lens from rear while tripping shutter.</p> <p><i>b.</i> Same as a above-----</p> <p><i>a.</i> View lens from rear while tripping shutter.</p> <p><i>b.</i> View lens from rear while tripping shutter.</p> <p>View lens from rear while tripping shutter.</p>	<p><i>a.</i> Shutter trips; actuate button operates without binding.</p> <p><i>b.</i> Shutter will not trip; double exposure prevention device operational.</p> <p><i>c.</i> Rotation is smooth and detent positive. Shutter trips and double exposure prevention device releases properly; shutter cocks.</p> <p><i>a.</i> Shutter trips and back assembly must be rotated to recock shutter.</p> <p><i>b.</i> Same as a above.</p> <p><i>a.</i> Shutter opens and remains open. Shutter will not trip again until back assembly is rotated. Rotating the back assembly does not close the shutter.</p> <p><i>b.</i> Shutter closes.</p> <p><i>a.</i> Shutter opens and remains open. Shutter closes when back assembly is rotated.</p>
9	None -----	None -----	<p>Inspect stereoscope; remove and reattach to camera assembly.</p>	<p>Assembly is undamaged. Mirrors clean and undamaged. Thumbscrew works normally and assembly attaches without binding.</p>
10	None -----	None -----	<p>Inspect density filter (cap and lens assembly). Remove and reattach to camera assembly.</p>	<p>Assembly clean and undamaged. Attaches firmly to lens and shutter assembly without binding or play.</p>
11	None -----	Operation of diaphragm and shutter speed adjustments.	<p>Inspect lens and shutter assembly. Check speed control and diaphragm adjustments.</p>	<p>No scratches on lens surfaces. Diaphragm adjusts smoothly but without play. Speed control operates smoothly with positive detent action.</p>

Step No.	Control settings		Test procedure	Performance standard
	Test equipment	Equipment under test		
12	None	Shutter speed control: 125. Connect shutter cord to jack on lens and shutter assembly. Set strobe assemblies function switch to position A(model 600) or to OFF position (model 700) and connect ac power cord.	a. Depress actuate button	a. Strobe assemblies flash in the ac mode.
13	Photoflood-lamp.	Load with black and white film.	b. Rotate back assembly. Change strobe assembly function switch to B (model600) or to ON position (model 700). Depress actuate button. <i>Refer to para 7-6d(s).</i> Expose all external areas of the camera assembly to the light from a No. 1 photofloodlamp at approximately 1 foot distance. Develop print.	b. Strobe assemblies flash in the battery mode. Print is completely black, no indication of light leakage.
14	None -----	<i>Refer to para 7-9b(5)</i> Density filters in place on lens and on strobe assembly. Black and white film load. Strobe assemblies: function switch in position A (model600) or OFF position(model 700) and ac power cord connected. Camera assembly: iris diaphragm at 5.6 and shutter speed control at 125.	<i>Refer to para 7-6d(4).</i> Position subject at titleboard and make exposure. Pull white and yellow film tabs and develop. Note. Characters may be placed on the titleboard to assist in checking focus.	Print has good focus and contrast. No fog or light streaks. No light leaks into unused half of frame. Note. Take into account the influence of ambient temperature on developing time.
15	None -----	As in step 1, but set strobe assembly function switch to position B (model 600) or ON position (model700).	Same as step 1, but rotate back assembly and make exposure on both halves of frame.	Print quality as described in step 1.
16	None -----	Remove density filters from lens and from strobe assembly. Disconnect shutter cord at jack on lens and shutter assembly. Adjust exposure with light meter (ASA 3000), but do not use T or B diaphragm settings.	Make an exposure with available light for an isolated test of the shutter; to test timing accuracy.	Print quality as described in step 1.
17	None -----	Same as step 1, but with density filters removed from lens and from strobe assembly. Remove the black and white film pack and use the color film pack.	Position subject at titleboard and make exposure. Rotate back assembly, and change strobe assemblies function switch to position B (model600) or OFF position (model700). Make a second exposure. Pull tabs and develop.	Print has good focus and contrast and good color fidelity. No appreciable difference between first and second exposure. No fog, light leaks, or scratches on emulsion.

Section V. EXTERNAL BATTERY CHARGER TESTS

7-10. External Battery Charger Test Procedure

a. *Test Equipment and Materials.* Type 53 lamp, 14.4 volts at 120 ma, with lamp socket and two probe leads.

b. *Test Connections and Conditions.* External battery charger connected to 115 vac 60-Hz power source.

c. Procedure

Step No.	Control settings		Test procedure	Performance standard
	Test equipment	Equipment under test		
1	Type 53 lamp with socket and probe leads.	Battery charger control set for 1 hour.	<p><i>Refer to para 7-6c.</i></p> <p>Time the timer. Place test lamp probes across rivet contacts in each charging position and verify charging current by observing test lamp illumination.</p>	<p>Timer times out in one hour±10%. Test lamp lights in each of the four charging positions.</p>

**APPENDIX A
REFERENCES**

The following publications contain information applicable to the direct and general support and depot maintenance of Camera Set, Still Picture, KS-19B.

TM 11-401	Elements of Signal Photograph.
TM 11-6625-203-12	Operator and Organizational Maintenance Multimeter AN/URM-105, including multimeter ME-77/U.
TM 11-6720-248-12	Operator's and Organizational Maintenance Manual, including Organizational Repair Parts and Special Tools List: Camera Set, Still Picture Model KS-19A4 and KS-19B.
DA Pam 310-4	Index of Technical Manuals, Technical Bulletins, Supply Manuals (Types 7, 8, and 9), Supply Bulletins, and Lubrication Orders.
DA Pam 310-7	U.S. Army Equipment Index of Modification Work Orders.

INDEX

	Paragraph	Page
Ac/Battery Operation:		
Model 700 Strobe-----	2-8g	2-5
Ac Operation:		
Model 600 Strobe-----	2-7f	2-4
Model 700 Strobe-----	2-8f, 2-12d	2-5, 2-10
Adjustable Cell:		
Disassembly-----	3-10f	3-6
Reassembly-----	3-11f	3-7
Adjustment:		
Camera Set-----	3-9	3-5
Focus-----	3-12	3-8
Back Assembly:		
Disassembly-----	3-10i	3-6
Battery Charger:		
Circuit Theory-----	2-11f	2-8
Model 600 Strobe-----	2-7e	2-4
Model 700 Strobe-----	2-8e, 2-12e	2-5, 10
Battery Charger, External-----	2-2e	2-1
Block Diagram-----	2-9	2-5
Theory of Operation-----	2-14	2-12
Battery Operation:		
Model 600 Strobe-----	2-7b	2-3
Model 700 Strobe-----	2-8b	2-5
Block Diagram:		
External Battery Charger-----	2-9	2-5
Model 700 Strobe-----	2-8	2-5
Block Diagram Theory:		
Camera Set-----	2-2	2-1
Exposure Control-----	2-2b	2-1
External Battery Charger-----	2-2e	2-1
Film Transport-----	2-2d	2-1
Image Characteristics-----	2-2a	2-1
Strobe Operation-----	2-2c	2-1
Camera Assembly:		
Disassembly-----	3-10	3-6
Reassembly-----	3-11	3-6
Tests-----	7-6d, 7-9	7-2, 7-4
Troubleshooting Chart-----	3-4a	3-2
Camera Back Assembly:		
Control Functions-----	2-5c	2-2
Camera Set:		
Adjustments-----	3-9	3-5
Block Diagram Theory-----	2-2	2-1
Disassembly-----	3-7	3-4
Mechanical Functions-----	2-3b	2-1
Reassembly-----	3-8	3-5
Control and Bypass Circuits:		
Model 600 Strobe-----	2-7c	2-4
Model 700 Strobe-----	2-8c	2-5
Control Functions:		
Camera Back Assembly-----	2-5c	2-2
Horizontal Positioning Bar-----	2-5d	2-3
Lens and Shutter Assembly-----	2-5b	2-2
Strobe Assembly-----	2-5e	2-3
Tripod-----	2-5a	2-2

	Paragraph	Page
Direct Support Maintenance:		
Test Equipment -----	3-2 <i>c</i>	3-1
Tools -----	3-2 <i>a</i>	3-1
Materials -----	3-2 <i>b</i>	3-1
Disassembly:		
Adjustable Cell -----	3-10 <i>f</i>	3-6
Camera Assembly -----	3-10	3-6
Camera Back Assembly -----	3-10 <i>i</i>	3-6
Camera Set -----	3-7	3-4
Door Assembly -----	3-10 <i>j</i>	3-6
External Battery Charger -----	3-17	3-14
Frame Support Assembly -----	3-10 <i>k</i>	3-6
Housing Adapter -----	3-10 <i>h</i>	3-6
Lens and Shutter Assembly -----	5-3	5-1
Main Support Casting -----	3-10 <i>g</i>	3-6
Model 600 Strobe -----	6-9	6-7
Model 600 Strobe Subassemblies -----	6-10	6-7
Model 700 Strobe -----	6-13	6-9
Model 700 Strobe Subassemblies -----	6-14	6-11
Support Arm Assembly -----	3-15	3-11
Tripod -----	3-13	3-8
Door Assembly:		
Disassembly -----	3-10 <i>j</i>	3-6
Reassembly -----	3-11 <i>c</i> , 3-11 <i>b</i>	3-7
Exposure Control:		
Theory of Operation -----	2-2 <i>b</i>	2-1
External Battery Charger:		
Disassembly -----	3-17	3-14
Reassembly -----	3-18	3-15
Tests -----	7-6 <i>e</i> , 7-10	7-2, 7-7
Troubleshooting Chart -----	3-4 <i>c</i>	3-3
Film Transport -----	2-2 <i>d</i>	2-1
Flash Synchronization -----	2-13 <i>c</i>	2-12
Focus Adjustment -----	3-12	3-8
Focus Test -----	5-8	5-4
Frame Roller Support Assembly:		
Disassembly -----	3-10 <i>k</i>	3-6
Reassembly -----	3-11 <i>a</i>	3-6
Function, Mechanical -----	2-3	2-1
Function, Optical -----	2-4	2-2
Housing Adapter:		
Disassembly -----	3-10 <i>h</i>	3-6
Reassembly -----	3-11 <i>d</i>	3-7
Horizontal Positioning Bar:		
Control Functions -----	2-5 <i>d</i>	2-3
Idle Mode Theory -----	2-11 <i>d</i>	2-8
Image Characteristics Theory -----	2-2 <i>a</i>	2-1
Iris Diaphragm Theory -----	2-13 <i>d</i>	2-12
Lens and Shutter Assembly:		
Disassembly -----	5-3	5-1
Control Functions -----	2-5 <i>b</i>	2-2
Focus Test -----	5-8	5-4
Operating Sequence -----	2-13 <i>a</i>	2-10
Physical Tests and Inspection -----	5-6	54
Reassembly -----	5-4	5-1
Testing -----	5-5, 5-7	5-2, 5-4
Theory of Operation -----	2-13	2-10
Main Support Casting:		
Disassembly -----	3-10 <i>g</i>	3-6
Reassembly -----	3-11 <i>e</i>	3-7

	Paragraph	Page
Oscillator:		
Model 700 Strob -----	2-12 <i>b</i>	2-8
Theory of Operation -----	2-11 <i>b</i>	2-7
Power Mode Theory-----	2-11 <i>c</i>	2-7
Publications Indexes-----	1-3	1-1
Reassembly:		
Adjustable Cell-----	3-11 <i>f</i>	3-7
Camera Assembly-----	3-11	3-6
Camera Set-----	3-8	3-4
Door Assembly-----	3-11 <i>c, 3-11b</i>	3-7
External Battery Charger -----	3-18	3-15
Frame Roller Support Assembly-----	3-11 <i>a</i>	3-6
Housing Adapter-----	3-11 <i>d</i>	3-7
Lens and Shutter Assembly-----	5-4	5-1
Main Support Casting -----	3-11 <i>e</i>	3-7
Model 600 Strobe -----	6-12	6-8
Model 600 Strobe Subassemblies-----	6-11	6-8
Model 700 Strobe -----	6-16	6-12
Model 700 Strobe Subassemblies-----	6-15	6-11
Support Arm Assembly -----	3-16	3-12
Tripod -----	3-14	3-8
SCR Control Assembly:		
Block Diagram -----	2-6	2-3
Theory-----	2-10	2-6
Troubleshooting Chart -----	3-4 <i>b</i>	3-3
Strobe Assembly:		
Control Functions-----	2-5 <i>e</i>	2-3
Operation-----	2-2 <i>c</i>	2-1
Strobe (Model 600):		
Ac Operation-----	2-7 <i>f</i>	2-4
Battery Charging-----	2-7 <i>e</i>	2-4
Battery Operation-----	2-7 <i>b</i>	2-3
Block Diagram -----	2-7	23
Control and Bypass Circuits -----	2-7 <i>c</i>	2-4
Disassembly -----	6-9	6-7
Reassembly-----	6-12	6-8
Tests -----	7-7, 7-6 <i>b</i>	7-2
Theory of Operation -----	2-11	2-6
Trigger Circuit -----	2-7 <i>d</i>	2-4
Troubleshooting Chart -----	6-6	6-2
Strobe (Model 700):		
Ac/Battery Operation -----	2-8 <i>g</i>	2-5
Ac Operation-----	2-8 <i>f, 2-12d</i>	2-5, 2-10
Battery Charging-----	2-8 <i>e, 2-12e</i>	2-5, 2-10
Battery Operation-----	2-8 <i>b</i>	2-5
Block Diagram -----	2-8	2-5
Control and Bypass Circuit-----	2-8 <i>c</i>	2-5
Disassembly -----	6-13	6-9
Oscillator -----	2-12 <i>b</i>	2-8
Reassembly-----	6-16	6-12
Tests -----	7-6 <i>c, 7-8, 6-20 7-2, 7-3, 6-16</i>	
Theory of Operation -----	2-12 2-8	
Trigger Circuit -----	2-12 <i>c, 2-8d</i>	2-10, 2-5
Troubleshooting Chart -----	6-7	6-3
Strobe Subassembly (Model 600):		
Disassembly -----	6-10	6-7
Reassembly-----	6-11	6-8
Strobe Subassembly (Model 700):		
Disassembly -----	6-14	611
Reassembly-----	6-15	6-11
Support Arm Assembly:		
Disassembly -----	3-15	3-11
Reassembly-----	3-16	3-12

	Paragraph	Page
Tests:		
Camera Assembly-----	7-6 <i>d</i> , 7-9	7-2, 7-4
External Battery Charger-----	7-6 <i>e</i> , 7-10	7-2, 7-7
Lens and Shutter Assembly-----	5-5, 5-7	5-2, 5-4
Model 600 Strobe-----	6-19, 7-6 <i>b</i> , 7-7	6-15, 7-2
Model 700 Strobe-----	6-20, 7-6 <i>c</i> , 7-8	6-16, 7-2, 7-3
Tests and Inspections:		
Physical-----	4-2 <i>e</i>	4-2
Operational-----	4-3	4-3
Theory of Operation:		
Battery Charger-----	2-11 <i>f</i>	2-8
Battery Charger, External-----	2-14	2-12
Flash Synchronization-----	2-13 <i>c</i>	2-12
Idle Mode-----	2-11 <i>d</i>	2-12
Iris Diaphragm-----	2-13 <i>d</i>	2-12
Lens and Shutter Assembly-----	2-13	2-10
Model 600 Strobe-----	2-11	2-6
Model 700 Strobe-----	2-12	2-8
Oscillator-----	2-11 <i>b</i>	2-7
Power Mode-----	2-11 <i>c</i>	2-7
SCR Control-----	2-10	2-6
Voltage Multiplier-----	2-11 <i>e</i>	2-8
Trigger Circuit:		
Model 600 Strobe-----	2-7 <i>d</i>	2-4
Model 700 Strobe-----	2-8 <i>d</i> , 2-12 <i>c</i>	2-5, 2-10
Tripod:		
Control Functions-----	2-5 <i>a</i>	2-2
Disassembly-----	3-13	3-8
Reassembly-----	3-14	3-8
Troubleshooting Chart:		
Camera Assembly-----	3-4 <i>a</i>	3-2
External Battery Charger-----	3-4 <i>c</i>	3-3
Model 600 Strobe-----	6-6	6-2
Model 700 Strobe-----	6-7	6-7
SCR Control Assembly-----	3-4 <i>b</i>	3-3
Voltage Multiplier Theory-----	2-11 <i>e</i>	2-8

By Order of the Secretary of the Army:

W. C. WESTMORELAND,
General, United States Army,
Chief of Staff.

Official:

KENNETH G. WICKHAM,
Major General, United States Army,
The Adjutant General.

Distribution:

Active Army:

USASA (2)
 CNGB (1)
 ACSC-E (2)
 Dir of Trans (1)
 CofEngrs (1)
 TSG (1)
 CofSptS (1)
 USAARENBD (2)
 USAMB (10)
 USACDC (2)
 USACDC Agcy (1)
 USAMC (1)
 CONARC (5)
 ARADCOM (2)
 ARADCOM Rgn (2)
 OS Maj Comd (4)
 USARYIS (5)
 LOGCOMD (5)
 USAMICOM (4)
 USATECOM (2)
 USASTRATCOM (4)
 USAESC (70)
 MDW (1)
 Armies (2)
 Corps (2)
 1st Cav Div (3)
 Svc Colleges (2)
 USASESS (10)
 USAADS (2)
 USAFAS (2)
 USAARMS (2)
 USAIS (2)
 USAES (2)
 USAINTS (5)
 WRAMC (1)
 USACDCEC (10)
 USMA (2)

AV Comm Cen (1)
 Instl (2) except
 Ft Gordon (10)
 Ft Huachuca (10)
 WSMR (3)
 Ft Carson (19)
 Ft Bragg (5)
 Army Dep (2) except
 LBAD (14)
 SAAD (30)
 TOAD (14)
 LEAD (7)
 NAAD (5)
 SVAD (5)
 ATAD (10)
 GENDEPS (2)
 Sig Sec GENDEPS (5)
 Sig Dep (2)
 SigFLDMS (2)
 ATS (1)
 USAERDAA (2)
 USAERDAW (5)
 USACRREL (2)
 MAAG (1)
 USARMIS (1)
 USAPA (10)
 Ft Campbell (5)
 USA Crim Inves Lab (3)
 52d USASA Sp Op Comd (2)
 Units org under fol TOE:
 11-95 (2)
 11-96 (2)
 11-158 (2)
 11-500 (AA-AC, FD, FE) (2)
 29-134 (2)
 29-136 (2)

NG: None.

USAR: None.

For explanation of abbreviations used, see AR 310-50.

COLOR CODE MARKING FOR MILITARY STANDARD CAPACITORS

GROUP I Capacitors, Fixed, Various-Dielectrics, Styles CM, CN, CY, and CB

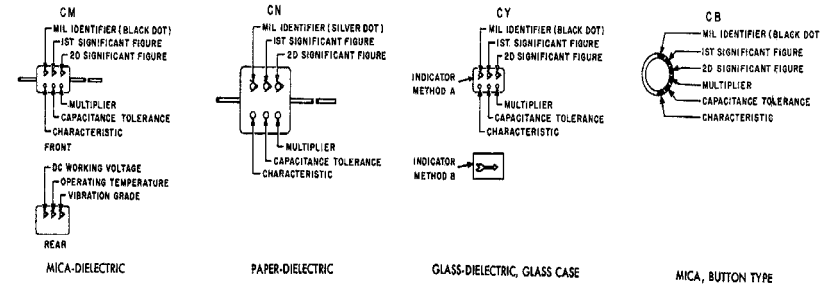

GROUP II Capacitors, Fixed Ceramic-Dielectric (General Purpose) Style CK

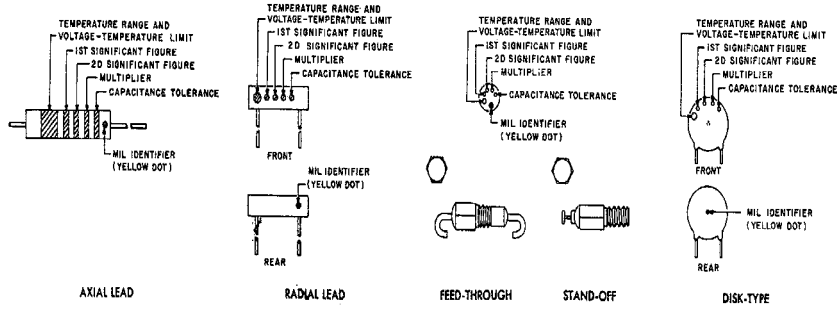

GROUP III Capacitors, Fixed, Ceramic-Dielectric (Temperature Compensating) Style CC

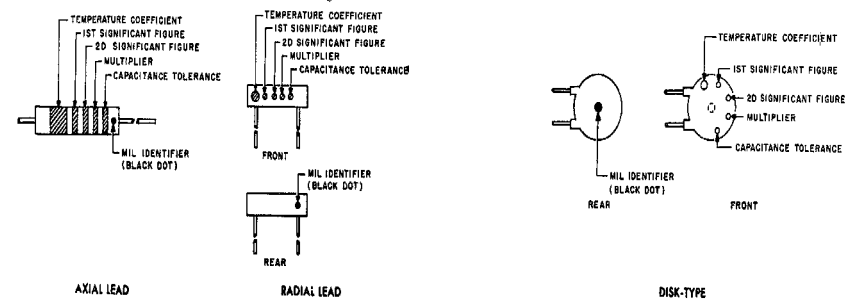

COLOR CODE TABLES

TABLE I - For use with Group I, Styles CM, CN, CY and CB

COLOR	MIL ID	1st SIG FIG	2nd SIG FIG	MULTIPLIER ¹	CAPACITANCE TOLERANCE				CHARACTERISTIC ²				DC WORKING VOLTAGE	OPERATING TEMP. RANGE	VIBRATION GRADE
					CM	CN	CY	CB	CM	CN	CY	CB			
BLACK	CM, CY, CB	0	0	1						A				-55° to +70°C	10-55 gpa
BROWN		1	1	10					B	F	B				
RED		2	2	100	± 2%		± 2%	± 2%	C		C			-55° to +85°C	
ORANGE		3	3	1,000	± 30%				D		D	300			
YELLOW		4	4	10,000					E					-55° to +125°C	10-2,000 gpa
GREEN		5	5		± 5%				F			500			
BLUE		6	6											-55° to +150°C	
PURPLE (VIOLET)		7	7												
GREY		8	8												
WHITE		9	9												
GOLD				0.1			± 5%	± 5%							
SILVER	CN				± 10%	± 10%	± 10%	± 10%							

TABLE II - For use with Group II, General Purpose, Style CK

COLOR	TEMP. RANGE AND VOLTAGE-TEMP. LIMITS ³	1st SIG FIG	2nd SIG FIG	MULTIPLIER ¹	CAPACITANCE TOLERANCE	MIL ID
BROWN	AW	1	1	10	± 10%	
RED	AX	2	2	100		
ORANGE	BX	3	3	1,000		
YELLOW	AY	4	4	10,000		CK
GREEN	CZ	5	5			
BLUE	BV	6	6			
PURPLE (VIOLET)		7	7			
GREY		8	8			
WHITE		9	9			
GOLD						
SILVER						

TABLE III - For use with Group III, Temperature Compensating, Style CC

COLOR	TEMPERATURE COEFFICIENT ⁴	1st SIG FIG	2nd SIG FIG	MULTIPLIER ¹	CAPACITANCE TOLERANCE		MIL ID
					Capacitances over 10µuf	Capacitances 10µuf or less	
BLACK	0	0	0	1		± 2.0µuf	CC
BROWN	-30	1	1	10	± 1%		
RED	-80	2	2	100	± 2%	± 0.25µuf	
ORANGE	-150	3	3	1,000			
YELLOW	-220	4	4				
GREEN	-330	5	5		± 5%	± 0.5µuf	
BLUE	-470	6	6				
PURPLE (VIOLET)	-750	7	7				
GREY		8	8	0.01			
WHITE		9	9	0.1	± 10%		
GOLD	*100					± 1.0µuf	
SILVER							

- The multiplier is the number by which the two significant (SIG) figures are multiplied to obtain the capacitance in µuf.
- Letters indicate the Characteristics designated in applicable specifications; MIL-C-5, MIL-C-91, MIL-C-11272, and MIL-C-10950 respectively.
- Letters indicate the temperature range and voltage-temperature limits designated in MIL-C-11015.
- Temperature coefficient in parts per million per degree centigrade.

COLOR CODE MARKING FOR MILITARY STANDARD RESISTORS

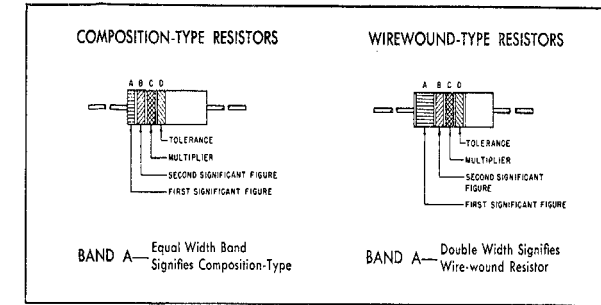

COLOR CODE TABLE

COLOR	FIRST SIGNIFICANT FIGURE	BAND B		BAND C		BAND D*	
		COLOR	SECOND SIGNIFICANT FIGURE	COLOR	MULTIPLIER	COLOR	RESISTANCE TOLERANCE (PERCENT)
BLACK	0	BLACK	0	BLACK	1		
BROWN	1	BROWN	1	BROWN	10		
RED	2	RED	2	RED	100		
ORANGE	3	ORANGE	3	ORANGE	1,000		
YELLOW	4	YELLOW	4	YELLOW	10,000	SILVER	± 10
GREEN	5	GREEN	5	GREEN	100,000	GOLD	± 5
BLUE	6	BLUE	6	BLUE	1,000,000		
PURPLE (VIOLET)	7	PURPLE (VIOLET)	7				
GRAY	8	GRAY	8	SILVER	0.01		
WHITE	9	WHITE	9	GOLD	0.1		

EXAMPLES OF COLOR CODING

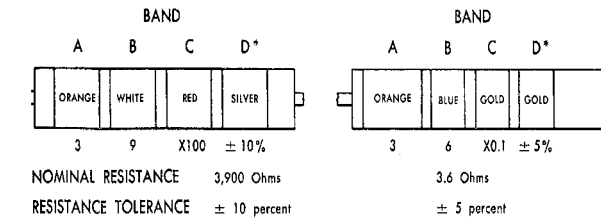

*If Band D is omitted, the resistor tolerance is ± 20%, and the resistor is not Mil-Std. ESC-PM-1113-69

Figure 6-13. Resistor-capacitor color code chart.

RECOMMENDED CHANGES TO EQUIPMENT TECHNICAL PUBLICATIONS



THEN... JOT DOWN THE DOPE ABOUT IT ON THIS FORM, CAREFULLY TEAR IT OUT, FOLD IT AND DROP IT IN THE MAIL!

SOMETHING WRONG WITH THIS PUBLICATION?

FROM: (PRINT YOUR UNIT'S COMPLETE ADDRESS)

DATE SENT

PUBLICATION NUMBER

PUBLICATION DATE

PUBLICATION TITLE

BE EXACT... PIN-POINT WHERE IT IS

IN THIS SPACE TELL WHAT IS WRONG AND WHAT SHOULD BE DONE ABOUT IT:

PAGE NO.

PARA-GRAPH

FIGURE NO.

TABLE NO.

TEAR ALONG PERFORATED LINE

PRINTED NAME, GRADE OR TITLE, AND TELEPHONE NUMBER

SIGN HERE:

DA FORM 2028-2
1 JUL 79

PREVIOUS EDITIONS ARE OBSOLETE.

P.S.—IF YOUR OUTFIT WANTS TO KNOW ABOUT YOUR RECOMMENDATION MAKE A CARBON COPY OF THIS AND GIVE IT TO YOUR HEADQUARTERS.

